

STARTRAC

OWNER'S MANUAL

263-4WD-8G-STAGE-V



8G
THE EIGHTH
GENERATION

EDITION - 210312
OWNER'S MANUAL -263 - 4WD - 8G - STAGE - V
www.captaintractors.com

OWNERSHIP AND TRACTORS DETAILS

DEALER COPY

OWNER'S NAME	
OWNER'S ADDRESS	

MODEL:		DELIVERY DATE:	
CHASSIS NO.:		INVOICE NO.:	
ENGINE NO.:		INVOICE DATE:	
BATTERY MAKE & SR.NO.:		ALTERNATOR MAKE & SR. NO.:	

TYRE TYPE:			
TYRE	MAKE	SIZE	SR. NO.
FRONT (LEFT)			
FRONT (RIGHT)			
REAR (LEFT)			
REAR (RIGHT)			

I have understood all the terms & conditions of the maintenance of the tractor, terms of warranty, systems, scheduled services & understood operation of tractor in the field and other operations.

Received a new defect free tractor & fully satisfied with the transaction.

DEALER STAMP & SIGNATURE	OWNER'S SIGNATURE PHONE NO. DATE:
--------------------------	---------------------------------------------------------------------

IMPORTANT INFORMATION TO CUSTOMER: For any assistance regarding our product, please contact our authorized dealer or authorized service center.

OWNERSHIP AND TRACTORS DETAILS

CUSTOMER COPY

OWNER'S NAME	
OWNER'S ADDRESS	

MODEL:		DELIVERY DATE:	
CHASSIS NO.:		INVOICE NO.:	
ENGINE NO.:		INVOICE DATE:	
BATTERY MAKE & SR.NO.:		ALTERNATOR MAKE & SR. NO.:	

TYRE TYPE:			
TYRE	MAKE	SIZE	SR. NO.
FRONT (LEFT)			
FRONT (RIGHT)			
REAR (LEFT)			
REAR (RIGHT)			

I have understood all the terms & conditions of the maintenance of the tractor, terms of warranty, systems, scheduled services & understood operation of tractor in the field and other operations.

Received a new defect free tractor & fully satisfied with the transaction.

DEALER STAMP & SIGNATURE	OWNER'S SIGNATURE
	PHONE NO. DATE:

IMPORTANT INFORMATION TO CUSTOMER: For any assistance regarding our product, please contact our authorized dealer or authorized service center.



PREFACE

Dear Customer,

We welcome you with great pleasure for joining CAPTAIN/ STARTRAC family and thanks for faith and trust you have placed in the careful selection of your tractor.

We are sure that our dealer must have taken good care while delivering tractor up to your satisfaction.

Before using tractor, it is recommended to read this manual thoroughly. Any person who uses the tractor should be also advised to read these instructions.

Daily and routine maintenance operations can be easily performed with the use of this manual. To get trouble free and best performance from your tractor. Please ensure for periodic maintenance as per recommended schedule in the owner's manual at authorized dealership.

Use only genuine spare parts from dealer/stockiest for reliable and durable performance.

Information provided in this operator manual is accurate at the time of printing. Improvements and modifications are a continuous process at **Captain Tractors Pvt. Ltd.** We therefore reserve the right for modification at any time without prior notice.

For any help/support feel free to call our dealership with the tractor details like Chassis Number (Vehicle Identification Number/ Serial Number), Engine number and Hour Meter Reading.

We wish you prosperity and growth.

Head Office / Plant:

Captain Tractors Pvt. Ltd.

Padavla Road, Veraval (Shapar)

Taluka: Kotda Sangani,

Dist. Rajkot (Gujarat), India

Phone: 02827-252547, 253916-17.

E-mail: exports@captaintractors.com

Website: www.captaintractors.com

TABLE OF CONTENTS

CHAPTER -1 TRACTOR IDENTIFICATION	13
1.1. VEHICLE IDENTIFICATION NUMBER (CHASSIS NUMBER).....	13
1.2. ENGINE SERIAL NUMBER	14
1.3. ROPS CERTIFICATE PLATE.....	14
1.4. UNIVERSAL SYMBOLS.....	15
CHAPTER -2 INTRODUCTION, WARRANTY & SAFETY NOTES	16
2.1 INTRODUCTION.....	16
2.2 WARRANTY PROCEDURE.....	16
2.3 PARTS WARNING.....	17
2.4 IF YOU MOVE	17
2.5 SERVICE AFTER WARRANTY	17
2.6 SAFETY.....	17
2.7 INTERNATIONAL WARRANTY POLICY FOR EU TRACTORS.....	18
2.8 MANDATORY SERVICES TO BE AVAILED BY CUSTOMERS TO BE ELIGIBLE FOR WARRANTY: ...	19
2.9 SAFETY ALERT SYMBOLS AND TERMS.....	20
2.10 SAFETY: INTRODUCTION	20
2.11 SAFETY: A WORD TO THE OPERATOR	21
2.12 SAFETY: DANGER, WARNING and CAUTION	21
2.13 SAFETY: DECALS	21
2.14 SAFETY: FOR SAFE OPERATION	22
2.15 SAFETY FRAME	23
2.16 OPERATION:	24
2.17 DAMAGE TO THE SAFETY FRAME:	25
2.18 PROTECT YOURSELF:	25
2.19 KNOW YOUR EQUIPMENT:	25
2.20 USE ALL AVAILABLE PROTECTIVE DEVICES:.....	26
2.21 CLEAN THE TRACTOR:	27
2.22 PROTECT THE ENVIRONMENT:	27
2.23 ONLY FOR NORTH AMERICA:	27
2.24 SERVICING THE TRACTOR.....	27
2.25 WARN BYSTANDERS BEFORE STARTING:	28

2.26	MOUNT AND DISMOUNT PROPERLY	28
2.27	START SAFELY	28
2.28	FOLLOW SAFE OPERATING PRACTICES	29
2.29	WATCH OUT FOR OTHERS.....	29
2.30	NEVER LIFT A LOAD OVER ANYONE	30
2.31	RISK OF OVERTURN	30
2.32	TO AVOID SIDE OVERTURNS:	30
2.33	TO AVOID REAR OVERTURNS.....	31
2.34	GENERAL OPERATING HAZARDS	32
2.35	ROAD TRANSPORT	33
2.36	ROAD REGULATIONS.....	34
2.37	NOISE CHARACTERISTICS AND MEASUREMENT	34
2.38	NOISE PATHOLOGIES.....	35
2.39	POSITION OF DECALS ON TRACTOR.....	36
CHAPTER -3 INSTRUMENTS AND CONTROLS.....		39
3.1	CONTROLS.....	39
3.2	INSTRUMENT PANEL	40
3.3	HOUR CUM RPM METER.....	40
3.4	ENGINE COOLANT TEMPERATURE GUAGE	40
3.5	FUEL LEVEL GAUGE	41
3.6	DASHBOARD.....	41
3.7	COMBINATION SWITCH FOR FOLLOWING OPERATIONS:	41
3.8	BATTERY CHARGING INDICATOR	42
3.9	DRIVER’S SEAT.....	42
3.10	TOOLBOX.....	43
3.11	UNDER HOOD MUFFLER	43
3.12	IGNITION KEY	43
3.13	HAZARD WARNING LIGHT SWITCH	43
3.14	HEAD LIGHTS & TAILLIGHTS	44
3.15	PLOUGH LIGHT	44
3.16	BATTERY ISOLATOR SWITCH	44
CHAPTER -4 OPERATION		45
4.1	BOARDING THE TRACTOR	45
4.2	LEAVING THE TRACTOR.....	45

4.3	STARTING THE ENGINE (IN SAFETY MODE – NEUTRAL POSITION ONLY)	45
4.4	COLD WEATHER STARTING (TEMPERATURES BELOW 0°C OR 32°F).....	45
4.5	RUNNING IN	46
4.6	AFTER STARTING THE ENGINE:	46
4.7	STOPPING THE TRACTOR:	47
4.8	TURNING OFF THE ENGINE	47
4.9	OPENING & CLOSING THE BONNET	47
4.10	ACCELERATOR PEDAL.....	47
4.11	CLUTCH PEDAL	47
4.12	GEAR SHIFTER LEVERS.....	48
4.13	SHIFTING SPEED RANGE SELECTOR LEVER.....	48
4.14	LEVER (2WD / 4WD).....	48
4.15	PTO (POWER TAKE OFF) lever.....	49
4.16	PRECAUTIONS WHEN USING THE PTO.....	49
4.17	A REQUIREMENT TO USE ONLY POWER TAKE-OFF DRIVE SHAFTS WITH ADEQUATE GUARDS50	
4.18	INFORMATION ABOUT USING IMPLEMENTS WITH PTO DRIVE SHAFTS.....	50
4.19	HAND THROTTLE LEVER	51
4.20	HYDRAULIC COUPLING DEVICES	51
4.21	POWER STEERING	51
4.22	POWER STEERING CIRCUIT DIAGRAM	52
4.23	TRANSPORT LOCK	52
4.24	DIFFERENTIAL LOCK	53
4.25	SERVICE BRAKE.....	53
4.26	PARKING BRAKE	53
4.27	PARKING BRAKE RELEASE.....	53
4.28	USE IN PADDY FIELDS.....	54
4.29	GROUND SPEED TABLES.....	54
4.30	WHEELS AND TYRES	55
4.31	TYRE PRESSURE IN FIELD OPERATIONS.....	55
4.32	TYRE PRESSURE IN ROAD OPERATIONS	56
4.33	TYRE BALLASTING.....	56
4.34	MECHANICALLY CONTROLLED POWER LIFT – HYDRAULIC SYSTEM	56
4.35	POSITION CONTROL (PC) LEVER.....	57
4.36	DRAFT CONTROL (DC) LEVER	57

4.37	THREE-POINT LINKAGE.....	57
4.38	ADJUSTABLE TOP LINK	57
4.39	ADJUSTABLE LIFT ROD OR LEVELING ROD	58
4.40	LATERAL STABILIZERS CHAIN	58
4.41	LOWER LINKS	58
4.42	HITCHING IMPLEMENTS.....	58
4.43	UNHITCHING IMPLEMENTS.....	59
4.44	HOW TO SAFELY DRIVE THE TRACTOR.....	59
4.45	TRANSPORT THE TRACTOR	59
	CHAPTER -5 MAINTENANCE.....	60
5.1	MAINTENANCE SCHEDULE	60
5.2	SEALED UNITS.....	61
5.3	RUNNING IN	61
5.4	HOW TO PREVENT POLLUTION	61
5.5	SERVING INTERVALS.....	62
5.6	MISCELLANEOUS INSPECTIONS.....	62
5.7	FUEL INJECTION PUMP.....	62
5.8	KEEP THE ENVIRONMENT CLEAN.....	62
5.9	ENGINE COOLING SYSTEM	62
5.10	RADIATOR	62
5.11	LUBRICATION	62
5.12	INDICATOR LIGHTS.....	63
5.13	FUEL TANK FILLING	63
5.14	FUEL REQUISITES.....	63
5.15	FUELING	63
5.16	FUEL STORAGE	63
5.17	ENGINE OIL LEVEL	64
5.18	RECOMMENDED ENGINE OIL VISCOSITY ACCORDING TO AIR TEMPERATURE	64
5.19	REAR TRANSMISSION, AND HYDRAULIC OIL LEVEL	64
5.20	RECOMMENDED GEAR OIL VISCOSITY ACCORDING TO AIR TEMPERATURE	65
5.21	FRONT DIFFERENTIAL OIL LEVEL	65
5.22	RADIATOR COOLANT LEVEL (HOT).....	66
5.23	PRECAUTIONS AGAINST FREEZING TEMPERATURES:.....	66
5.24	REPLACEMENT OF ENGINE OIL FILTER.....	66

5.25	CHANGINE AND REFILLING OF ENGINE OIL	67
5.26	REPLACEMENT OF ENGINE FUEL FILTER	67
5.27	AIR BLEEDING OF FUEL SYSTEM.....	67
5.28	REPLACEMENT OF TRANSMISSION, REAR FINAL DRIVES AND POWER LIFT HYDRAULIC CIRCUITS OIL	68
5.29	RADIATOR DRAINING & FLUSHING (WHEN COLD)	68
5.30	RADIATOR FINS CLEANING.....	69
5.31	RADIATOR CAP	69
5.32	CHECK OR REPLACE HOSE PIPES	69
5.33	DRY TYPE AIR FILTER	69
5.34	IMPORTANT INSTRUCTIONS FOR AIR FILTER.....	70
5.35	CLEANING OF SUCTION STRAINER.....	70
5.36	STEERING CYLINDER KNUCKLE.....	70
5.37	CLUTCH PEDAL	71
5.38	METHOD TO CHECK CLUTCH PEDAL FREE PLAY.....	71
5.39	METHOD TO ADJUST CLUTCH PEDAL FREE PLAY	71
5.40	BRAKE PEDAL	71
5.41	METHOD TO CHECK BRAKE PEDAL FREE PLAY.....	71
5.42	METHOD TO ADJUST BRAKE PEDAL FREE PLAY	72
5.43	PARKING BRAKE	72
5.44	BATTERY	72
5.45	BATTERY REMOVAL PROCEDURE.....	73
5.46	CHECK ELECTROLYTE LEVEL	73
5.47	BATTERY CHARGING PROCEDURE.....	73
5.48	BATTERY REPLACEMENT PROCEDURE	74
5.49	HAZARD RELATED TO BATTERY.....	74
5.50	AVOID BATTERY HAZARD BY:.....	74
5.51	IF ACID IS SPILLED ON SKIN OR IN EYES	75
5.52	IF ACID IS SWALLOWED.....	75
5.53	ALTERNATOR (12V, 65A).....	75
5.54	STARTER MOTOR (12V, 1.6kW).....	75
5.55	CHECKING V-BELT.....	75
5.56	ADJUSTING V-BELT TENSION:	75
5.57	MISCELLANEOUS INSPECTIONS.....	76

5.58	DASHBOARD CONTROL COATINGS	76
5.59	FUSES	76
5.60	SEVEN PIN SOCKET FOR TRAILER	76
5.61	CONNECTION FOR SEVEN PIN SOCKET	77
5.62	LONG IDLE PERIOD.....	77
5.63	GREASING POINTS AVAILABLE ON THE TRACTOR.....	78
5.64	GREASING POINTS.....	79
5.65	WIRING CIRCUIT DIAGRAM.....	80
	CHAPTER -6 TECHNICAL SPECIFICATION	81
	OVERALL DIMENSION	82
	CHAPTER - 7 DO' AND DON'TS	83
	CHAPTER - 8 TROULESHOOTING	87
	1 ST SERVICE COUPON	90
	2 ND SERVICE COUPON	92
	3 RD SERVICE COUPON	94
	4 TH SERVICE COUPON	96
	5 TH SERVICE COUPON	98

CHAPTER -1 TRACTOR IDENTIFICATION

1.1. VEHICLE IDENTIFICATION NUMBER (CHASSIS NUMBER)

- Vehicle Identification number is punched on left hand side of the front axle bracket chassis. If you find the number difficult to read, you will also find it on the statutory plate which is located on Right Side of the chassis front.



Vehicle Identification
Number Location

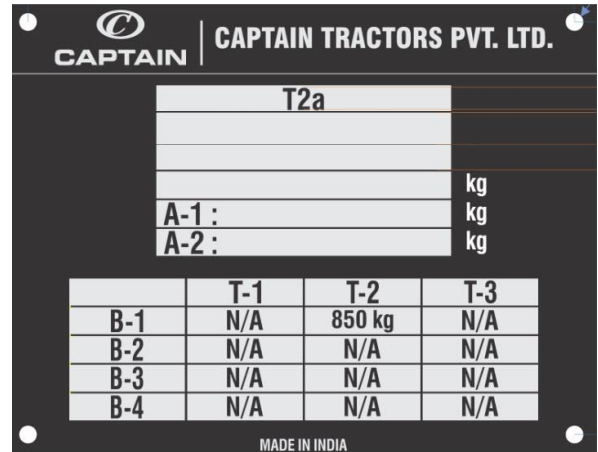

Statutory Plate Location

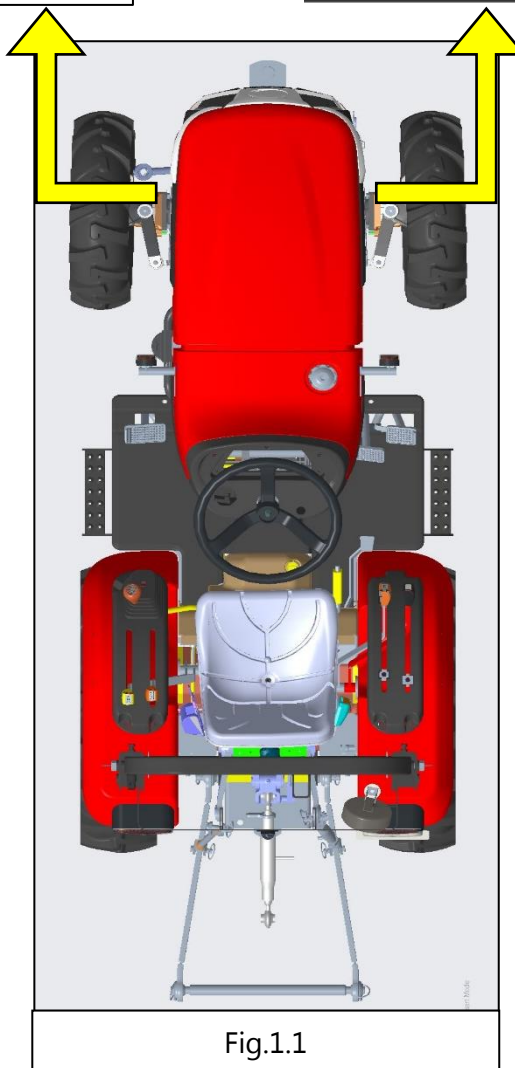

Fig.1.1

1.2. ENGINE SERIAL NUMBER

The engine serial number is stamped on the upper side of the fuel injection pump installation part located in the right side of cylinder block.

Always state the chassis and engine serial number to ensure prompt and efficient service when ordering spare parts or when asking for technical explanations or other information.

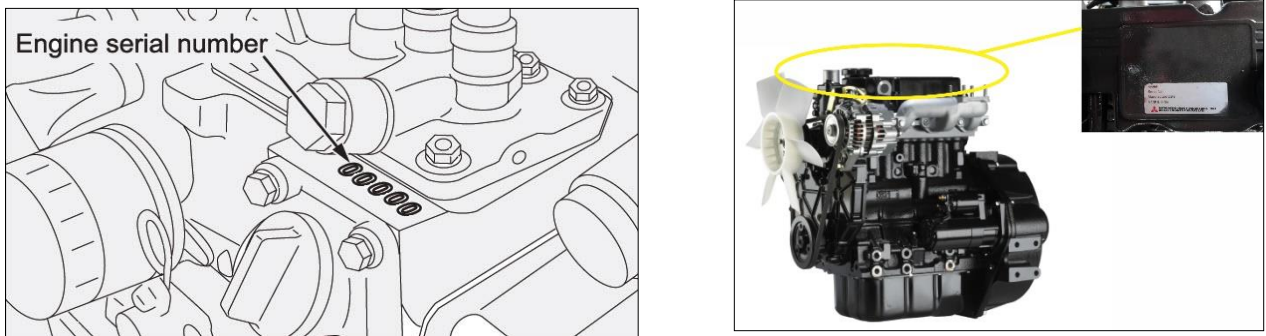

Fig 1.2

1.3. ROPS CERTIFICATE PLATE

ROPS certificate plate is riveted on right side ROPS as shown in Fig. Information about ROPS serial number and tractor model is inscribed on ROPS plate.

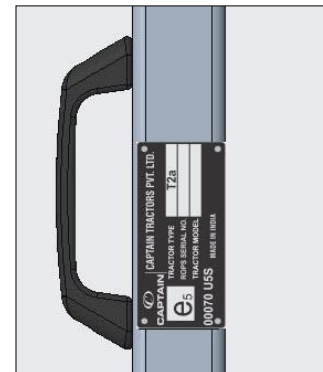























Fig 1.3

NOTE: Look after this Operation and maintenance Manual carefully and consult it whenever in doubt. This publication has been written in compliance with International Standard ISO 3600 'Guide for information, contents and presentation of operation and maintenance manuals supplied with tractors and machinery for agricultural and forestry use.

1.4. UNIVERSAL SYMBOLS

As a guide to the operation of your, various universal symbols have been utilized on the instruments and controls. The symbols are shown below with an indication of their Meaning.

	Hazard Warning Lights		Four Wheel Drive – On
	Read operator Manual		Four Wheel Drive - Off
	Position Lamps		Fast
	Headlight Beam		Slow
	Parking Brake		Engine On
	Engine Coolant Temperature		Engine Start
	Battery Charging Condition		Engine Shut off
	Engine Oil – Pressure		Power Take-off clutch control – 540 RPM
	Turn Signal		Power Take-off clutch control – NETURAL
	Engine Speed Control		Power Take-off clutch control – 1000 RPM
	Position Control – Lowered Position		Position Control – Raised Position

CHAPTER -2 INTRODUCTION, WARRANTY & SAFETY NOTES

2.1 INTRODUCTION

This book is published for worldwide distribution, and availability of equipment shown either as basic or accessory may vary according to the territory in which the tractor is to be operated. Full details of equipment available in your area can be obtained from your Dealer.

The purpose of this book is to enable the owner and driver to operate the tractor in a safe manner. Providing that the instructions are followed carefully, the tractor will give years of service in our tradition.

The installation of the product by the Dealer gives the opportunity to ensure that the operating and maintenance instructions are understood. Always consult your Dealer if do not understand any part of this book. It is important that these instructions are understood and observed. Daily maintenance should become a routine, and a record of hours in service should be kept.

When new parts are required it is important that only genuine service parts are used. Our Authorized Dealers supply genuine parts and can give advice regarding their fitment and use. Extensive damage may occur as a result of the fitment of parts of inferior quality, Customers are advised to buy their service parts only from an authorized Dealer.

Owing to wide variations in operating conditions, it is impossible for the Company to make comprehensive or definitive statements in its publications regarding performance or methods of use of its machines, or to accept liability for any loss or damage which may result from these statements, or from any errors or omissions. If the tractor is to be used for abnormal conditions which may be detrimental (e.g. deep water / paddy fields) consult your Dealer for special instructions, or the warranty may be invalidated.

These tractors are designed solely for use in customary agricultural operations (intended use). Use in any other way is considered as contrary to the intended use. The tractor manufacturer accepts no liability for any damage or injury resulting from misuse and these risks must be borne solely by the user. Compliance with, and strict adherence to, the conditions of operation, service and repair as specified by the manufacturer also constitute essential elements for the intended use. These tractors should be operated, serviced and repaired only by persons familiar with all their characteristics and who are acquainted with the relevant safety rules (accident prevention). Customers are strongly advised to use an official authorized Dealer in connection with any service problems and adjustment that may occur.

2.2 WARRANTY PROCEDURE

Correct installation, coupled with regular maintenance, will do much to prevent breakdowns. If, however, operating trouble is experienced during the warranty period, the following procedure must be adopted: -

Immediately notify the Dealer from whom you purchased the tractor, quoting the Model and Serial Number. It is most important that there should be no delay, and you should realize that, even where the original failure is covered by warranty. If the failure is not repaired immediately

warranty cover may not apply. Provide your Dealer with as much background information as you can. It will help him to know how many hours service has been achieved, the type of work on which you are engaged and the symptoms of the trouble.

It should be noted that normal maintenance services such as tuning, brake/clutch adjustments, and the supply of materials used to service the tractor (oil, filters, fuel and antifreeze) are not covered by terms of the warranty.

2.3 PARTS WARNING

The fitment of non-genuine parts may result in a part of substandard quality being used. The tractor manufacturer will not take the responsibility for any loss, damage or liability resulting from the fitment of such parts and if fitted during the normal warranty period the manufacturer's warranty may be invalidated.

2.4 IF YOU MOVE

Only the official dealer from whom you purchase the tractor is responsible for the protection afforded by your warranty and where possible, you should always take the tractor to him for repair. However if you move to another area or if your tractor should be working temporarily at some distance from the Dealer from whom it was purchased, you are recommended to obtain from the original Dealer the name and address of the Dealer nearest to your new location and to ask for arrangements to be made for outstanding service warranty commitments to be transferred to the latter. If you have left the area in which the original Dealer operates and have not made arrangements with your new Dealer, the latter will readily provide assistance in emergency, but you will be charged at normal rates for any work undertaken unless:

You make it clear that the warranty has not expired, and You give the repairing Dealer the opportunity to make suitable arrangements with the retailing Dealer. However, you moved outside of the operation area of retail dealer and if there is no dealer in that particular region, then the warranty cannot be availed.

2.5 SERVICE AFTER WARRANTY

During the warranty period, you should have all your repairs and maintenance performed by your dealer. This ensures that a detailed check is kept on the progress and performance of your new tractor.

In order to obtain the best results from your tractor it is important that regular maintenance and service checks continue after the warranty period has expired. Make use of your local Dealer for all major tractor services; a trained engineer will spot any problems between the service and the next.

The mechanics are regularly trained and updated on the product, servicing techniques and the use of modern service tools and diagnostic equipment. They receive regular Service Bulletins; have all Workshop Manuals and other such technical information to ensure that the repair or service is to the standard required.

2.6 SAFETY

The safety of operator is one of the main concerns in designing and developing a new tractor. Designers build in as many safety features as possible. However, every year many accidents occur which could have been avoided by a few seconds thought and a more careful approach to handling farm machinery and implements.

2.7 INTERNATIONAL WARRANTY POLICY FOR EU TRACTORS

Under the policy Warranty applicable only to first retail purchaser.

Under the policy, tractors manufactured by company and delivered to end customers through company's authorized dealers are warranted for free replacement of parts with MANUFACTURING defect within a period of 730 days from date of installation (sale/delivery) OR 1000 Hours from date of installation (sale/delivery) OR 900 Days from the Date of B/L, whichever occurs earlier, provided all the below mentioned mandatory services have been availed by the customer in the specified time period.

Defective parts are identified as original parts fitted on tractor as per approval but are not as per company's drawings and there is a manufacturing defect observed in it.

Defective parts are to be replaced free of cost by area dealer who further gets free replacement or equivalent credit amount from company under specified procedure of warranty, provided the cost of an individual item or part is above EURO 10.

LABOUR charges will be borne by the dealer.

FOLLOWING PARTS ARE NOT COVERED UNDER WARRANTY ----

(A)--- Rubber parts inclusive of oil seals, O' rings, joints & gaskets.

(B)--- Electricals such as bulbs, fuses, wiring harness & switches.

(C)--- Items subject to wear & tear such as Brake linings, clutch linings, etc.

(D)--- Consumable items such as Lubricants, Filter elements, etc.

- Parts damaged due to misuse, accident, use of non-recommended implements will not be considered under warranty.
- All warranty claims are subject to mandatory services taken from authorized dealers & coupons submitted to dealer for onward submission to company.
- Sole authority to accept/ reject warranty claim lies with company's management.

WARRANTY OF SPECIFIC ITEMS SUCH AS:

TIRES/TUBES: Wear and Tear is not covered under warranty

BATTERY: Warranty is limited to 12 months from the date of B/L provided correct installation and regular maintenance has been carried out.

2.8 MANDATORY SERVICES TO BE AVAILED BY CUSTOMERS TO BE ELIGIBLE FOR WARRANTY:

1st Service within 01 month from the date of delivery or 50 hours, whichever occurs earlier.

2nd Service within 03 months from the date of delivery or 250 hours, whichever occurs earlier.

3rd Service within 06 months from the date of delivery or 500 hours, whichever occurs earlier.

4th Service within 12 months from the date of delivery or 750 hours, whichever occurs earlier.

5th Service within 18 months from the date of delivery or 1000 hours, whichever occurs earlier.

Address for submission of warranty claims: -

To,
Service Department
Captain Tractors Pvt. Ltd.
Padavla Road, Veraval (Shapar),
Taluka: Kotda Sangani,
Dist. Rajkot (Gujarat), India
Phone: 02827-252547, 253916-17.
E-mail: customercare@captainagri.com
Website: www.captaintractors.com

2.9 SAFETY ALERT SYMBOLS AND TERMS

This safety alert symbol means ATTENTION! BECOME ALERT! YOUR SAFETY IS INVOLVED!



The safety alert symbol identifies important safety messages on machines, safety signs, in manuals or elsewhere. When you see this symbol, be alert to the possibility of personal injury or death.

Why is SAFETY important to you?

***ACCIDENT DISABLE and KILL* * ACCIDENTS are COSTLY * ***

ACCIDENTS can be AVOIDED

SAFETY: TRACTOR and IMPLEMENT

- The tractor is a source of power: Both mechanical and hydraulic.
- On its own, the tractor is of little practical value. Only when used in conjunction with an implement or other attachment does it become a working unit.
- This instruction book is compiled to cover those safe working practices that are associated with the base tractor operation.
- It does not cover all operation and safety instructions relevant to all known implements and attachments that may be fitted at the time of tractor delivery or at some future date.
- It is essential that operators use and understand the relevant instruction manual of such implements and attachments.

2.10 SAFETY: INTRODUCTION

This safety section of your Operator Instruction book is intended to point out some of the basic safety situations which may be encountered during the normal operation and maintenance of your PLATFORM, and to suggest possible ways of dealing with these situations. This section is NOT a replacement for other safety practices featured in other sections of this book. Additional precautions may be necessary depending on attachments used and conditions at the work site or in the service area. The tractor manufacturer has no direct control over tractor application, operation, inspection, lubrication or maintenance. Therefore, it is YOUR responsibility to use good safety practices in these areas.

2.11 SAFETY: A WORD TO THE OPERATOR

It is YOUR responsibility to read and understand the safety section in this manual before operating your tractor. You must follow these safety instructions that take you step by step through your working day

In reading this section, you will note that illustrations have been used to highlight certain situations. Each illustration is numbered, and the same number appears in the text in parenthesis. This number is placed at the end of the written text that refers to the illustration and is made up of two digits, separated by a hyphen: the first digit designates the chapter, the second one of the figure number in that chapter (e.g. Fig.2-30 of chapter 2). Remember that YOU are the key to safety. Good safety practices not only protect you, but also the people around you. Study the features in this manual and make them a working part of your safety program. Keep in mind that this safety section is written only for this type of machine. Practice all other usual and customary safe working precautions, and above all remember are the key to SAFETY IS YOUR RESPONSIBILITY. YOU CAN PREVENT SERIOUS INJURY.

2.12 SAFETY: DANGER, WARNING and CAUTION

Whenever you see the words and symbols shown below, used in this book and on decals, you must take note of their instructions as they relate to personal safety.



DANGER: The symbol and the word DANGER indicates an imminently hazardous situation, which, if not avoided, will result in DEATH OR VERY SERIOUS INJURY.



WARNING: The symbol and the word WARNING indicate a potentially hazardous situation. If the instructions or "procedures are not correctly followed it could result in DEATH OR SERIOUS INJURY.



CAUTION: The symbol and the word CAUTION indicate a "potentially hazardous situation, which, if not avoided, may result in MINOR INJURY.

IMPORTANT:

The word IMPORTANT is used to identify special instructions or procedures which, if not strictly observed, could result in damage to, or destruction of the machine, process or its surroundings.

NOTE:

The word NOTE is used to indicate point of interest for more efficient and convenient repair or operation.

2.13 SAFETY: DECALS

Replace any DANGER, WARNING, CAUTION or Instruction Decals that are not readable or are missing. Replacement decals are available from your Dealer in the event of loss or damage. The actual location of these safety Decals is illustration at the end of this section.

If a used tractor has been purchased, refer to the illustration at the end of this section to ensure that all the safety WARNING decals are in the correct position and are readable.



DO NOT remove or obscure DANGER, WARNING, CAUTION or Instruction decals.

2.14 SAFETY: FOR SAFE OPERATION

For safe operation of an agricultural tractor, you must be a qualified and authorized operator. To be qualified you must understand the written instructions supplied in this Operator Instruction Book, have training, and know the safety rules and regulations for the job.

Some regulations specify, for example, that no one under the age of 18 years (according to European Rules) may operate power machinery. This includes tractor, it is your responsibility to know what these regulations are, and obey them, in the operating area of situation.

These will include, but are not limited to, the following instructions for safe tractor operations:



An operator should not use alcohol or drugs which can change his/her alertness or co-ordination. An operator on prescription or 'over the counter' drugs needs medical advice on whether he or she can properly operate machines.

OBSERVE THE FOLLOWING PRECAUTIONS:

1. NEVER allow children or unqualified persons to operate your tractor. Keep others away from your area of work.
2. Securely fasten your seat belt when the tractor has a safety frame in the upright position.
3. Where possible, avoid operating the tractor near ditches, embankments and holes.
4. Reduce speed when turning, crossing slopes, and on rough, slippery, or muddy surfaces.
5. Stay off slopes too steep for safe operation.
6. Watch where you are going, especially at row ends, on roads, and around trees.
7. DO NOT permit others to ride on the tractor or the implement unless an approved passenger seat is fitted.
8. Hitch only to the drawbar and recommended hitch points, and never above the center line of the rear axle.
9. Operate the tractor smoothly - no jerky turns, starts or stops, when the tractor is stopped, apply the parking brakes securely.
10. Never modify or remove any part of the equipment and never use attachments unless they are properly matched to your tractor.
11. Lock the tractor brake pedals together when transporting on roads to provide proper wheel braking.
12. Keep the tractor in the same gear when going downhill as used when going uphill. Do not coast or free wheel down hills.
13. Any towed vehicle and/or trailer whose total weight exceeds that of the towing tractor, must be equipped with its own brakes for safe operation.
14. When the tractor is stuck or tyres are frozen to the ground, back out to prevent upset.
15. Always check overhead clearance, especially when transporting the tractor.

2.15 SAFETY FRAME

- A Safety Structure (ROPS – Roll Over Protection Structure) and seat with belt are fitted as standard equipment to the platform tractor at the time of factory assembly and approved according to the CURRENT OECD and EEC STANDARDS.
- The protective structure is formed by three parts, one upper and two lowers, which are bolted together.
- The tractor must only be used with the protective structure in the upright position (Fig. 2.1).
- If the safety frame was deleted by the original purchaser or has been removed, it is recommended that you equip your tractor with a Safety Structure and a seat belt.
- Safety frames are effective in reducing injuries during overturn accidents.
- A tractor overturning without safety frame can result in serious injury or death.
- Depending on laws in force in the various markets, a seat with belt may be installed.
- Always raise the safety frame before installation or use. Always raise the safety frame before fastening the seat belt.
- If a fold-down safety frame is installed. DO NOT wear a seat belt when the safety frame is in folded down position.
- NEVER keep the safety frame in the folded down position when working with the tractor.



Fig.2.1



The tractor could tip up if used incorrectly. Protection is only guaranteed when the protective structure is in its original upright position with the fixing bolts tightened as described in the assembly instructions.

To Avoid injury! Make sure that certain all parts are installed correctly.

- Safety belts can be fitted, depending on the laws in force in the various countries of use. Always wear the safety belts with the protective structure in the upright position.
- Never wear the safety belts when the protective structure is lowered.
- If the tractor must pass through low places or be parked there for maintenance purposes and the top part of the protective structure must be folded at an angle remember that there is not enough protection for the tractor driver in this position and that he could risk serious injury.
- Remember that after use in low places, it is necessary to set the protective structure back in its upright position (Fig. 2-1) before continuing with any work.

Comply with the following procedure if it is essential to fold down the protective structure for the above reasons:

1. Remove the fixing pins (2).
2. Lower the protective structure (1) slowly until it rests on the stopper. Be careful do not injured yourself.
3. Fit the fixing pins (2) and relative nuts as illustrated.
4. Before you use the tractor again in any way, set the protective structure (1) back in the upright position (Fig. 2.1) by carrying out the operation described above in reverse order. Fit the fixing pins.

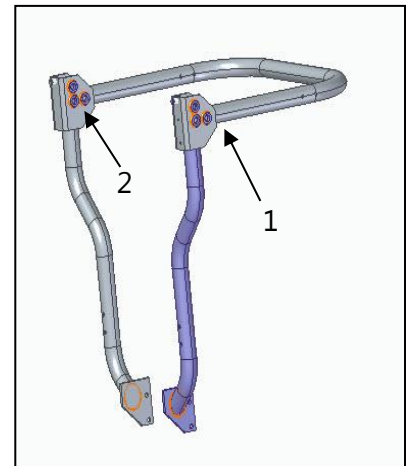

Fig.2.2

- To avoid loosening of structure the protection offered by the safety structure will be impaired if it is subjected to structural damage, as in an overturn accident, or is in anyway altered by welding, bending, drilling or cutting.
- A damaged safety structure should be replaced, NOT reused.
- Always keep upper part of the safety structure pinned in vertical position (as in the above Fig.2.1) when operating the tractor.
- If the tractor is operated with the safety structure folded down (e.g. to enter a low building) drive with extreme caution and DO NOT use seat belt.
- Fold the safety structure up again as soon as the tractor is operated under normal conditions.

2.16 OPERATION:

Before using the tractor ensure that the safety frame is not damaged, that it is securely fastened to the tractor, and, if a hinged section is fitted, that it is in the raised position and secured.

If the safety frame has been removed from the tractor, or folded down for a specific operation, it must be refitted or erected immediately using the proper hardware and applying the recommended torque value.

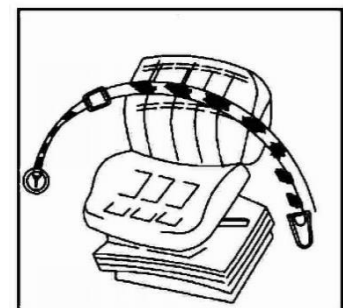

Fig.2.3

DO NOT ATTACH chains, ropes or cables to the safety frame for pulling purposes; this will cause the tractor to tip backwards. Always pull from the tractor drawbar.

If a seat belt is installed, always wear your seat belt-adjusted snugly except when operating with a folded down safety frame or if the safety frame has been removed.

Check the seat belt for damage. A damaged seat belt must be replaced.

2.17 DAMAGE TO THE SAFETY FRAME:

If the tractor has rolled over or the safety frame has been damaged (such as striking an overhead object during transport), the safety frame must be replaced to provide the original degree of protection.

After an accident, check for damage to the safety frame operator's seat, seat belt and seat mountings. Before you operate the tractor, replace all damaged parts.



DO NOT WELD, DRILL, BEND OR STRAIGHTEN THE SAFETY FRAME. IF DONE, IT WILL REDUCE THE PROTECTION IT OFFERS.
IT WILL REDUCE THE PROTECTION IF ANY OF THE ABOVE POINT IS NOT TAKEN IN CONSIDERATION.
THE COMPANY ASSUMES NO LIABILITY TOWARDS DISREGARDS OF THE ABOVE SAFETY POINT.

2.18 PROTECT YOURSELF:

Wear all the protective clothing and personal safety devices issued to you or called for by job conditions. Don't take risk. Hence you should carry/wear the following (fig. 2.4)

- A. A hard hat.
- B. Safety glasses, goggles or face shield.
- C. Hearing protection.
- D. Respirator or filter mask.
- E. Inclement weather clothing.
- F. Reflective clothing.
- G. Heavy gloves (neoprene for chemical, leather for rough work).
- H. Safety shoes.

NOTE:

1. DO NOT wear loose clothing, jewelry or other items and tie up long hair which could catch on controls or other parts of the tractor.
2. Learn where fire extinguishers and first aid or emergency equipment is kept and where to get help in a hurry. Make sure you know how to use this equipment.

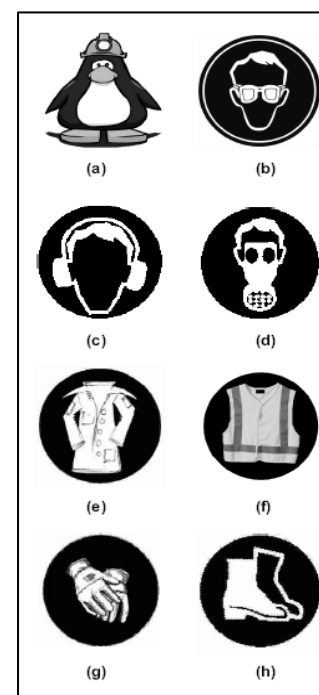

Fig.2.4

2.19 KNOW YOUR EQUIPMENT:

Know how to operate all equipment on your machine and the implements and attachments used with it. Know the purpose of all the controls, gauges and dials. Know the rated load capacity, speed range, braking and steering characteristics turning radius and operating clearances. Keep in mind that rain, snow, ie, loose gravel, soft ground, etc. can change the way your tractor operates. Under poor conditions, slow down and be extra careful, engage four-wheel drive, if fitted.

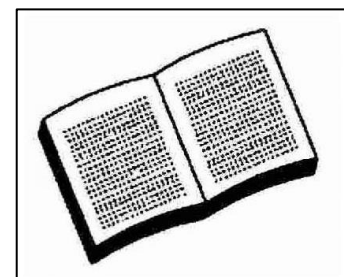

Fig.2.5

Study the DANGER, WARNING or CAUTION safety signs on your tractor and the information signs also. Read this operator instruction book before starting the engine. Study it before you start the work.

If there is something in the manual you don't understand, ask someone (such as your equipment dealer) to explain it to you.

IMPORTANT: This manual covers general safe practices for agricultural tractor it must always be kept with the tractor. For

further copies contact you're Dealer.

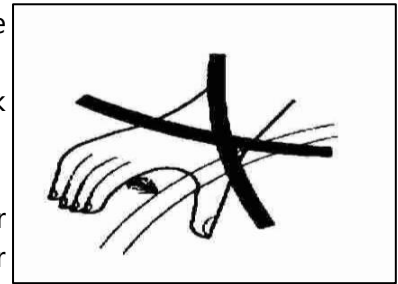

Fig.2.6

2.20 USE ALL AVAILABLE PROTECTIVE DEVICES:

DO NOT smoke while refueling the tractor. Keep any type of open flame away. Check for loose, broken, missing, or damaged parts. Have everything put into good repair. Make certain all safety devices are in place.

Check safety frame and seat belt for damage. A damage safety frame or seat belt MUST be replaced. Ensure that implements and attachments are properly installed and that the tractor and implement P.T.O. RPM ratings match.

Check the tires for cuts, bulges and correct pressure. Replace worn or damaged tires. Check foot and parking brakes for proper operation. Adjust if necessary.

- Stop the engine and wait for it to cool before refueling. Check the engine oil level and add oil if required.
- Perform all maintenance procedures outlined in the maintenance and adjustment section of this manual.
- Check that the PTO drive locking devices are latched.
- Check that the tractor PTO shield and driveline guards are in place and operating properly.
- Check the tractor and implement hydraulic system. Have any leaks or damaged parts repaired or renewed.



DIESEL FUEL OR HYDRAULIC FLUID UNDER PRESSURE CAN PENETRATE THE SKIN OR EYES AND CAUSE SERIOUS PERSONAL INJURY, BLINDNESS OR DEATH. FLUID LEAKS, UNDER PRESSURE, MAY NOT BE VISIBLE. USE A PIECE OF CARDBOARD OR WOOD TO FIND LEAKS. NEVER USE YOUR BARE HAND. (FIG. 2-6) WEAR SAFETY GOGGLES FOR EYE PROTECTION. IF ANY FLUID IS INJECTED INTO THE SKIN, IT MUST BE SURGICALLY REMOVED WITHIN A FEW HOURS BY A DOCTOR FAMILIAR WITH THIS TYPE OF INJURY.

Before applying pressure to the fuel or hydraulic system, be sure all connections are tight and that lines, pipes, and hoses are not damaged. Before disconnecting fuel or hydraulic lines, be sure to relieve all pressure. Make sure that all hydraulic lines are correctly installed and not tangled.



LIQUID COOLING SYSTEMS BUILD UP ' PRESSURE AS THE ENGINE GETS HOT. BEFORE REMOVING THE RADIATOR CAP, STOP THE ENGINE AND LET THE SYSTEM COOL. CHECK THE ENGINE COOLING SYSTEM AND ADD COOLANT AS REQUIRED.

2.21 CLEAN THE TRACTOR:

- Keep work surfaces and engine compartments clean.
- Before cleaning the machine, always lower implements to the ground, place transmission in neutral, engage the parking brake, shut off the engine and remove the key.
- Clean steps, pedals and floor. Remove grease or oil, Brush away dust or mud.
- In winter scrape away snow and ice. Remember-slippery surfaces are dangerous.
- When plastic parts need to be cleaned (such as console, instrument panel, indicators etc.) do not use petrol, paraffin, diluents etc. they could cause discoloration, cracking or warping of the cleaned parts.
- These parts should ONLY be cleaned with water, neutral soap and a soft cloth.
- Remove and store implements, keys, hitches etc. in their proper places.

2.22 PROTECT THE ENVIRONMENT:

It is illegal to pollute drains, water courses or soil. Use authorized waste disposal facilities, including civic amenity sites and garages providing facilities for disposal of used oil. If in doubt, contact your local authority for advice. To get to know the correct methods to dispose of oils, filters, tires etc. contact your Dealer or the local agency for waste recycling.

2.23 ONLY FOR NORTH AMERICA:

The safety sheets of each material give information on chemicals contained in a product, procedures to use it safely, first-aid and procedure to be followed in case of leakage or spills. In all North America such safety sheets are available at the Dealer's. Before any maintenance on the machine refer to the above-mentioned safety sheets for fluids, oils etc. used in this machine. The sheets inform about risks and safe maintenance procedures. We strongly recommended following these indications during any maintenance operations.

Disposal of the tractor: The tractor is made up of parts subjected to rules and laws for their disposal. When the tractor is not used any more, it must be disposed of through proper agencies according to such rules. Do not pollute the environment with the tractor or its parts

2.24 SERVICING THE TRACTOR

- DO NOT service the tractor while the engine is running or hot, or if the tractor is in motion.
- Before adjusting, or servicing the electrical system, disconnect the battery cables, negative (-) cable first.
- To prevent fires or explosions keep open flames away from the battery to cold weather starting aids. To prevent sparks which could cause explosion use jumper cables according to instructions.
- When making repairs or adjustments it is recommended that you consult your Dealer, and have the work carried out by trained personnel.
- The implement and/or tractor must be supported on suitable wooden blocks or stands, NOT a hydraulic jack.
- Check all nuts and bolts periodically for tightness especially wheel hub and rim nuts. Tighten to the prescribed torque values.
- Check the power steering reservoir regularly and top up as necessary with approved oil.
- Check the brakes regularly, top up the reservoir and/or adjust where necessary. Make sure that the brakes are evenly adjusted.

2.25 WARN BYSTANDERS BEFORE STARTING:

Before starting, Walk all around the tractor and any attached equipment. Make sure that no one is under it, on it, or close to it. Let other workers and bystanders know you are starting up and don't start until everyone is clear of the tractor, implements and towed equipment.



ENSURE THAT ALL BYSTANDERS, PARTICULARLY CHILDREN ARE IN A SAFE POSITION BEFORE STARTING THE ENGINE.

2.26 MOUNT AND DISMOUNT PROPERLY

Always use 'three-point contact' with the machine and face the machine when you mount it. Three-point contact means both hands and one foot or one hand and both feet are always in contact with the machine during mounting and dismounting.

Clean the soles of your shoes and wipe your hands before climbing on. Use handrails, grip handrails, ladders or steps (as provided) when mounting or dismounting.

NEVER use control levers as a hand hold and NEVER step on foot controls when mounting or dismounting.

NEVER attempt to mount or dismount from a moving tractor. NEVER jump off a tractor in any circumstances.

2.27 START SAFELY



BEFORE STARTING THE ENGINE, MAKE SURE THERE IS PLENTY OF VENTILATION. NEVER OPERATE THE ENGINE IN A CLOSED BUILDING. THE EXHAUST FUMES MAY CAUSE ASPHYXIATION.

Always start the engine from the operator's seat with all the transmission levers and PTO lever in neutral.

Make sure that the tractor dual brake pedals are always locked together unless you are making turns in the field which require independent use of the brakes. Make sure the brakes are properly adjusted so that both brakes engage at the same time.

Adjust the seat, fasten the seat belt (where applicable as outlined in this manual), apply the parking brake and put all controls in neutral before starting up.

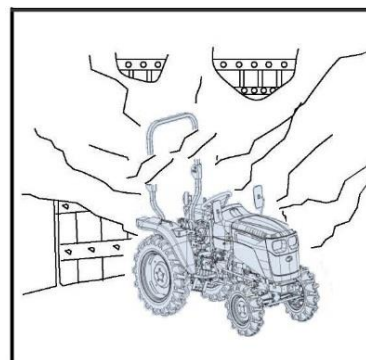

Fig.2.7



START THE ENGINE, WITH THE STARTER KEY, FROM THE OPERATOR'S SEAT ONLY. NEVER ATTEMPT TO START THE ENGINE BY SHORTING ACROSS THE STARTER TERMINALS. THE MACHINE WILL START IN GEAR IF THE NEUTRAL START CIRCUIT BYPASSED. THIS COULD CAUSE SERIOUS INJURY OR DEATH TO ANYONE NEAR THE TRACTOR.



Fig.2.8

2.28 FOLLOW SAFE OPERATING PRACTICES

- Operating the controls smoothly: don't jerk the steering wheel or other controls.
- DO NOT get on or off a moving tractor, always keep a firm grip on the steering wheel, with the thumbs clear the spokes when driving the tractor.
- Make sure you have adequate clearance in all directions for tractor, safety frame and implement.
- NEVER play games with a tractor or equipment.
- NEVER attempt to work the controls expect from the operator's seat.
- Before getting off the tractor, always disengage the PTO, lower all attachments and implements to the ground, place the tractor in neutral, engage parking brake, shut off the engine and remove the key.
- DO NOT touch, lean on, or reach through any implement mechanism or permit others to do so. Stay alert.
- Should something break, come loose, or fail to operate in your equipment, stop work, shut off the engine, inspect the machine and have repairs or adjustments made before resuming operation.

2.29 WATCH OUT FOR OTHERS

Be aware of what is going on. Never allow an untrained or unqualified person to operate your tractor. They could injure themselves or someone else.



YOUR TRACTOR IS A ONE-PERSON MACHINE. DO NOT PERMIT OTHERS TO RIDE ON THE TRACTOR OR THE IMPLEMENT



Fig.2.9

In some countries a passenger seat must be fitted to carry passengers. Never allow anyone to ride on the implements or other equipment including trailers, except on certain harvesting equipment, specially designed for riders during the actual harvest operation only (not during transport). Such equipment must have provision for a safe riding area. NEVER allow children on a tractor.



ACCIDENTAL CONTACT WITH HIGH- VOLTAGE, LINES CAUSE DEATH. IN CASE OF CONTACT WITH HIGH - VOLTAGE CONDUCTORS DO NOT LEAVE THE TRACTOR; BID MOVE THE TRACTOR AND/OR THE LOADER IN SUCH A WAY AS TO ELIMINATE THE CONTACT AND REACH A SAFE DISTANCE

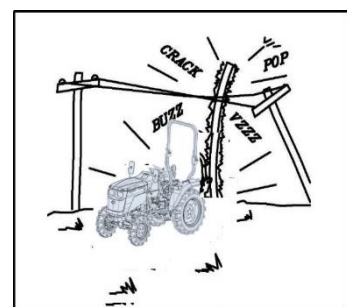

Fig.2.10

2.30 NEVER LIFT A LOAD OVER ANYONE

- Keep others away from your operation. Never allow anyone to stand or pass under a raised implement.
- DO NOT lift object that cannot be contained safely in the bucket gets the appropriate attachment.
- Never allow anyone to stand on the safety frame or fenders.
- When using a loader, avoid sudden stops, starts, turns, or change of direction. Keep loads as near to the ground as possible.
- Never stand (or allow anyone else to stand) in front of, under, or behind loaded or loading equipment.
- Never drive a tractor up to someone standing in front of a fixed object.
- Keep others away from articulation joints, itches, drawbar, lift arm, PTO drive, cylinders, belts, pulleys, and other moving parts. Keep all shields and guards in place.

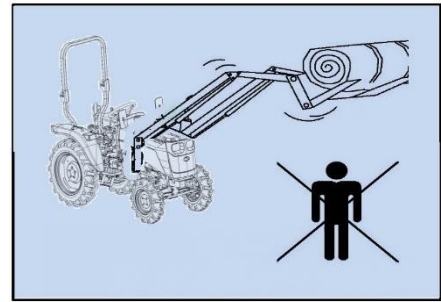

Fig.2.11

2.31 RISK OF OVERTURN

For your safety, it is recommended that your tractor is fitted with safety frame and seat belts.

In the event of overturning with a tractor fitted with a safety frame, hold the steering wheel firmly and DO NOT attempt to leave the seat until the tractor has come to rest.

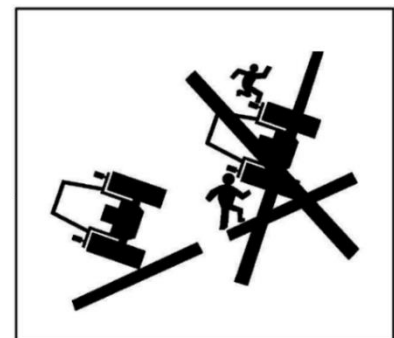

Fig.2.12

2.32 TO AVOID SIDE OVERTURNS:

- Set the wheel track at the widest setting suitable for the job being done.
- Lock the brake pedals together before driving at transport speeds.
- Reduce speed to match operating conditions. If the tractor is equipped with a front-end loader carry the bucket and load as low as possible.
- Make wide slow turns at reduced speed. DON'T let your tractor bounce. You may lose steering control.
- DON'T pull a load too heavy for your tractor. It could run away on the down slope or the tractor could jack knife around a towed load.
- DON'T brake suddenly. Apply brakes smoothly and gradually.
- When going down a slope use the throttle to slow the tractor engine and use the same gear you would use to up the slope. Shift into gear before you start downhill.



NEVER STAND OR ALLOW ANYONE ELSE STAND BETWEEN THE TRACTOR AND IMPLEMENT UNLESS THE ENGINE IS TURNED OFF PARKING BRAKES IS ENGAGED, THE TRANSMISSION IS IN NEUTRAL, AND ALL ATTACHMENTS OR IMPLEMENTS ARE LOWERED TO THE GROUND. NEVER DISENGAGE THE CLUTCH OR ATTEMPT TO SHIFT GEAR AFTER YOU HAVE STARTED DOWNHILL.

- It is always preferable to straight up or down a steep slope rather than across it.
- Avoid crossing steep slopes if possible. If you must do so, avoid any holes or depressions on the downhill side. Avoid any stumps rocks, bumps or downhill side. Avoid any stumps

rocks, bumps or raised areas on the uphill side. When operating near ditches or banks always keep your tractor behind the shear line.

- If it is necessary to cross a steep slope, avoid turning uphill, slope down and make a wide turn. Travel directly up or down the slope, never across it. When traveling up or down a slope, keep the heavy end of the tractor pointed uphill.
- When traveling across a slope with side mounted avoid crossing steep slopes if possible. If you must do so, avoid any holes or depressions on the downhill side. Avoid any stumps, rocks, bumps or raised areas on the uphill side.

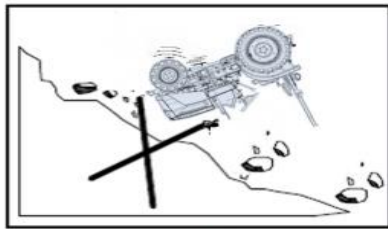

(Fig.2-14)

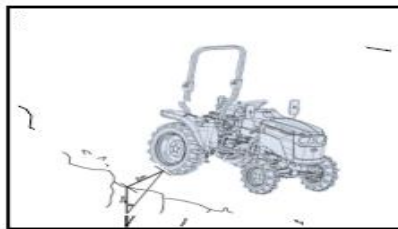

(Fig.2-15)

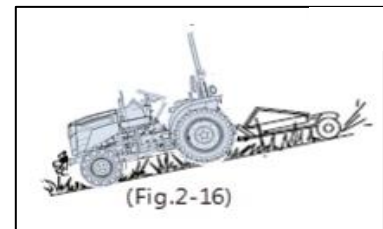

(Fig.2-16)

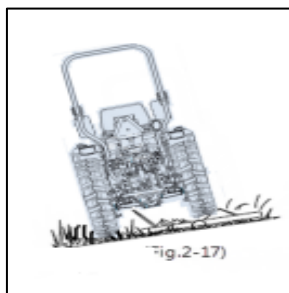

(Fig.2-17)

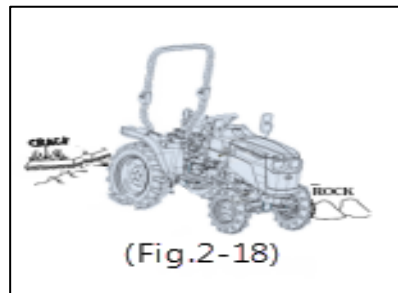

(Fig.2-18)

2.33 TO AVOID REAR OVERTURNS

DO NOT pull anything using the top link connection, or from any point above the center line of the rear axle. Always use an approved drawbar, and only use a drawbar pin that locks into place.

High hitching can cause rear overturn, which may cause serious injury or death. Hitch loads to the drawbar only.

When using a three-point linkage drawbar, the stays must be fitted and kept in the down position.

Use front counterweights to increase tractor stability when towing a heavy load or to counterbalance a heavy rear mounted implement (fig.20). Hitching to the rear axle, or any other point above the swinging drawbar, can cause a rear overturn do not overload your tractor and DO NOT ballast it beyond its carrying capacity. Never add ballast weight to counterbalance an overload. Reduce the load instead.

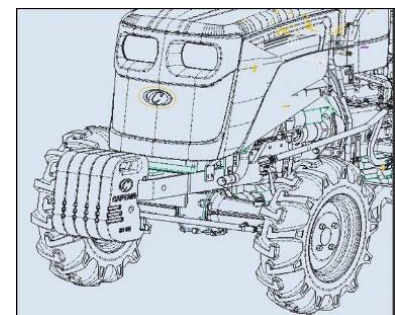

Fig.2.19

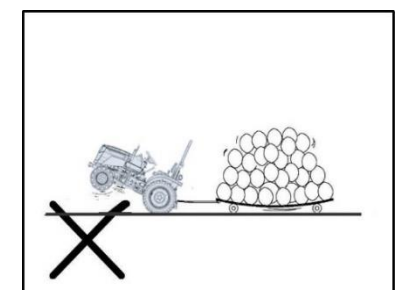

Fig.2.20



An overload is always dangerous. Check the loading capacity of your tractor and NEVER overload

If the front end of the tractor starts to lift, reduce your speed and, if necessary, disengage the clutch. If your tractor is bogged down in the mud or frozen to the ground, DO NOT attempt to drive forwards.

The tractor can rotate around its rear wheels and overturn. Lift any attached implement and attempt to BACK OUT. If this is not possible, tow it out with another vehicle.

Start forward slowly and gradually increase your speed. DO NOT rev the engine or drop the clutch. If the tractor is attached to a heavy load, or immovable object, improper clutching may cause overturn.

If you get stuck in a ditch, BACK OUT, if possible. If you must go forward, do it slowly, and carefully

A bare tractor or a tractor with rear mounted attachments should be backed up the slope in reverse and travel forward downhill. A tractor with a loaded front end bucket should be backed down the slope and travel forward uphill. Keep the loader bucket as low as possible. Always keep the tractor in gear when going downhill never permit the tractor to coast with clutch disengaged or transmission in neutral.

2.34 GENERAL OPERATING HAZARDS

Ensure that the PTO shield (2) is in place and that the cap is fitted at point (1) when the PTO driveline is not in use.

Before attaching, detaching, cleaning or adjusting PTO driven implements, disengage the PTO, stop the engine remove the key, and make sure that the PTO driveline has stopped.

Ensure that all the PTO driveline guards are in place and observe all safety signs.

Be sure everyone is clear of your machine before engaging the PTO. For stationary PTO operation, always place transmission in neutral, engage parking brake and lock both tractor and implement wheels.

When operating mobile PTO driven equipment, never leave the tractor seat until the PTO drive is disengaged, the transmission is in neutral, the parking brake is engaged, the engine shut off and the key removed.

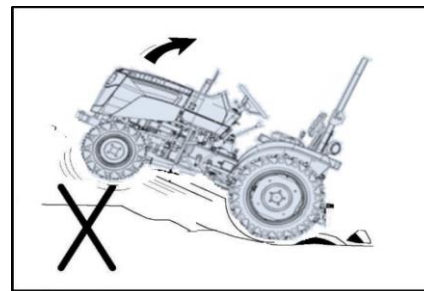

Fig.2.21

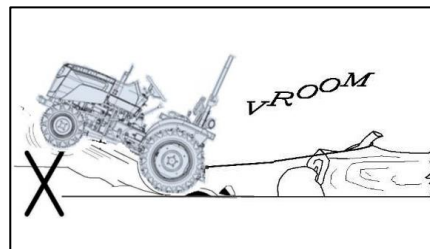

Fig.2.22

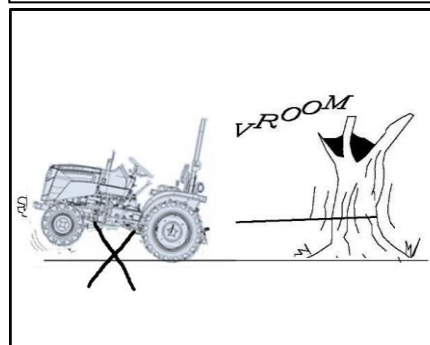

Fig.2.23

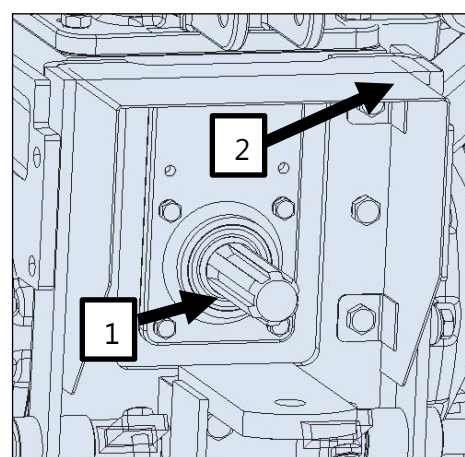

Fig.2.24

DO NOT use PTO adaptors, reducers or extensions as they extend the PTO coupler and universal joint out beyond the protection offered by the PTO shield. The top link rods must not be extended beyond the point where threads begin to show. Fig.2-25



NEVER attempt to unplug the hydraulic connections or adjust an implement with the engine running or the PTO drive in operation. To do so may result in serious injury or death. Do not make sharp turns at high speed.

When using chemicals, carefully follow the chemical manufacturer's instructions for use, storage and disposal. Also follow the chemical application equipment manufacturer's instructions.

When operating under poor visibility conditions, or in the dark, use your ground speed. (DO NOT use your field lights when traveling on a roadway because rear pointed white lights are illegal except when reversing and may confuse following drivers).

Operate your tractor with the wheels set the widest setting possible, consistent with the task you are performing. To adjust wheel settings, refer to Maintenance and Adjustment section.

Reduce your speed when operating over rough or slippery ground when foliage restricts your view of hazards.



A front-end loader (bucket or forks) must be equipped with a suitable restraining device to prevent the load, bales, fence posts, rolls of fence, wires etc.) From rolling down the lift arms into the operator's compartment and crushing the driver when the loader is raised.



Inadequately secured objects could also fall and injure bystanders. Do not use implements for different purpose or to handle materials they are not expected to. For the operation of front loaders and relative safety rules, please refer to the Operation Manual of the loader.

Three-point hitch and side mounted implements make a much larger arc when turning that towed equipment. Make certain to maintain enough clearance for safe turning.

When using attachments or implements with the tractor, be sure to thoroughly read the Operator Instruction Book for that attachment or implement and follow its safety instructions. Pull only from the approved drawbar. Towing or attaching to other locations may cause the tractor to overturn (Fig.2-26). Improper use of the drawbar, even if correctly positioned, may cause the tractor to overturn to the back. DO NOT overload an attachment or towed equipment Use proper counterweights to maintain tractor stability. Hitch loads to the drawbar only.

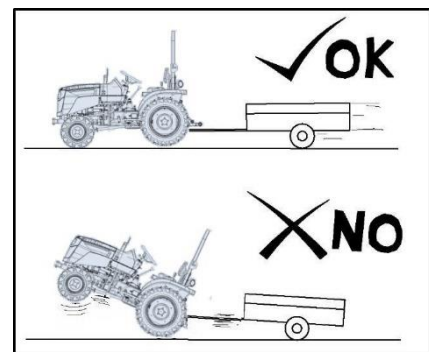

Fig.2.25

2.35 ROAD TRANSPORT

Before operating your tractor on a public road, several precautions must be taken.

- Familiarize yourself - and comply - with all local bylaws, and national laws appropriate to your tractor.
- Lock your brake pedals together.

- Raise all implements to their transport position and lock them in place.
- Place all implements into their narrowest transport configuration.
- Disengage the PTO.
- Make sure any required clearance flags or hazard lights are in place and in working order.
- Make sure you use a proper hitch pin with a clip retainer.
- Clean off all road lights, front and rear, and be certain they are in working order.
- Implements mounted on the 3-point hitch and mounted implements projecting from the side need a wider turn radius than trailed implements. Always be sure to keep.

2.36 ROAD REGULATIONS

When operating your tractor on a public road several precautions must be taken.

- Know the route you are going to travel.
- Use flashing lights when traveling on roads, day or night, unless prohibited by law.
- Use caution when towing a load at transport speeds especially if the towed equipment is NOT equipped with brakes.
- Observe all local or national regulations regarding the road speed of your tractor.
- Use extreme caution when transporting on snow- covered or slippery roads.
- Wait for traffic to clear before entering a public road.
- Beware of blind intersections. Slow down until you have a clear view.
- DO NOT attempt to pass at any intersection. Slow down for turns and curve.
- Make wide, gentle turns.
- Signal your intent to slow, stop or turn.
- Shift to lower gear before going up or down hills.
- Keep tractor in gear. Never coast with the clutch disengaged or transmission in neutral.
- STAY OUT of the path of oncoming traffic.
- Drive in your correct lane keeping as near to the kerb as possible.
- If traffic builds up behind you, pull off the road and let the road and let it go by.
- Drive defensively. Anticipate what other drivers might do.
- When towing a load, start braking sooner than normal and slow down gradually. Watch out for overhead obstructions.
- When Stopping at any time, bring the tractor to a secure halt (DO NOT park on a slope), apply the parking brake, engage the Park lock (if installed), disengage the PTO, Place all gear shift levers in neutral ,lower the implement to the ground , stop the engine and remove the key BEFORE leaving the seat



DO NOT ALLOW ANY PASSENGERS ON THE TRACTOR OR TOWED EQUIPMENT.

2.37 NOISE CHARACTERISTICS AND MEASUREMENT

- Noise is a pressure variation in an elastic medium, generally the air, produced by the variation of a material body (source) that determines an undesired and often annoying acoustic sensation. Noise is mainly characterized by:
- Sound intensity or level expresses the entity of the pressure variation due to the sound wave. Measured in decibels (dB), it doubles the sound intensity and, thus, the energy that reaches the ear.

- How the risk is evaluated: The higher the sound level and exposure time, the greater the noise risk will be:
- LAeq: (Equivalent continuous weighted level A): this is a sound level measurement that considers noise fluctuations and the varying sensitivity of the ear to the frequencies: LAeq is measured with a sound level meter;

2.38 NOISE PATHOLOGIES

Damage to the hearing

Noise causes hyperdulia or deafness because it destroys the acoustic receptors, nervous cells able to transform the mechanical sound vibrations into nervous impulses that, on reaching the brain, determine the aural sensation. These receptors are irreplaceable if they are destroyed and the resulting damage is irreversible: hyperdulia worsens if exposure to noise continues and does not improve even if this terminates.

Moreover, it is also bilateral since it can be accompanied by annoying buzzing and whistling sounds, and by intolerance to loud noise. The damage is insidious since it proceeds slowly and unexpectedly: in the initial phase, when it is limited to a diminished ability to perceive acute sounds (music, bells) or the spoken voice when there is a background noise, it can only be detected by means of an audiometric test. Pulsating noises of great intensity lasting a very short time are highly damaging since the ear is unable to actuate any physiological protective measures in time. Hyperdulia from noise generally arises after several years of exposure and depends on the PEL (risk almost null below 80 dBA) and on individual characteristics. It is an incurable disease: the only efficacious means of protection against it is prevention.

Other effects

Noise does not just determine aural sensation. For levels exceeding* 70dBA, it causes stress by means of the cerebral integration centers and determines a specific neurovegetative reaction responsible for effects that lead to cardio circulatory and gastro enteric diseases. Amongst these, it is worthwhile noting: an increase in gastric acidity, a decrease in the heart rate, visual range and reflex speed; a sensation of discomfort and weariness with an increased sense of fatigue. These effects are dangerous because they also increase the risk of accidents.

Personal equipment to protect against noise

Individual protective equipment attenuates the sound energy transmitted to the ear through the air. This equipment is used when dangerous exposure cannot be avoided in any other way. There are different types of devices with different attenuating capacities: helmets, earmuffs, ear plugs (Fig.2-29). Helmets and earmuffs offer the greatest protection, but they are bulky and inconvenient to wear. They are

therefore only of use for exposure to high noise levels but for short periods of time (max. 2 hours).

Ear plugs are generally tolerated to a greater extent and are of particular use in the case of lengthy exposure to noise of a lesser intensity. Always use adequate individual protective equipment to safeguard the hearing when the personal daily level of exposure to noise is 85 dBA or more. Consult the "specifications" chapter of this manual in relation to tractor noise measured in instantaneous conditions in compliance with the laws in force. Usage of above protection is advised in all conditions/ circumstances.



Fig.2.26

2.39 POSITION OF DECALS ON TRACTOR

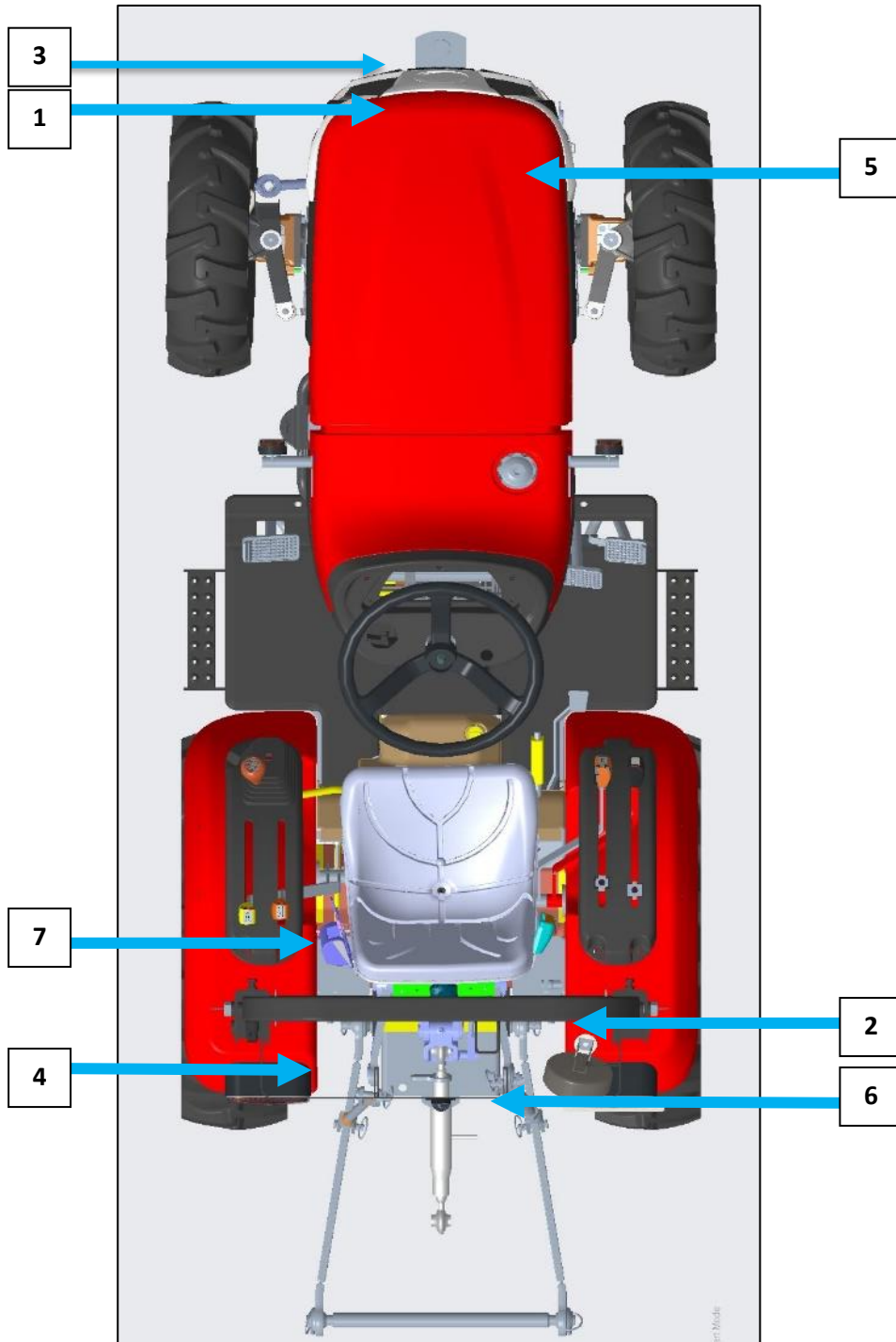

Fig.2.27

⚠ WARNING

- COOLING SYSTEM REMAINS UNDER PRESSURE.
- DO NOT REMOVE RADIATOR CAP WHEN SYSTEM IS HOT.
- ALWAYS TURN THE CAP SLOWLY AND ALLOW PRESSURE TO ESCAPE BEFORE REMOVING THE CAP COMPLETELY.
- WHEN OPERATING BELOW 0°C, USE SUITABLE ANTIFREEZE WITH WATER.

1



SAFETY INSTRUCTION

- It is essential to read The Manual carefully.
- Do not take off belt or Adjustment while Tractor is Running.
- Do not enter or exit from the Tractor while is in motion except in an emergency.
- Do not stand in-between the Tractor and Equipment when operating control.
- Keep clothing hand and feet away from moving parts.
- Do not make any adjustment when tractor is in operation.
- Wear adequate Footwear and snug-fitting clothing. Do not sit or stand on unsafe place when Tractor is moving.
- Keep Display Boards, Handles and Drivers Position Clean.
- Keep All Safety Guards in place While working.
- Make sure that no trains are coming before crossing the unguarded railway crossing

2

⚠ DANGER

- KEEP FLAMES AWAY FROM BATTERY.
- DISCONNECT -ve CABLE OF BATTERY BEFORE ANY WELDING OPERATION.
- PROTECT YOURSELF FROM BATTERY, FLAME BURNS CAN RESULT FROM BATTERY ACID.
- IN CASE OF CONTACT WITH ACID, FLUSH WITH PLENTY OF WATER IMMEDIATELY.
- DO NOT JUMP START THE TRACTOR BY SHORTING ACROSS STARTER TERMINALS AS TRACTOR WILL MOVE IF IN GEAR.

3

⚠ WARNING

- READ THE OPERATOR MANUAL CAREFULLY BEFORE STARTING THE TRACTOR. FOR QUERIES CONTACT AUTHORIZED DEALER.
- CLEAR THE AREA OF BY-STANDERS.
- UNDERSTAND OPERATION AND LOCATION OF CONTROLS.
- START ENGINE ONLY FROM DRIVER SEAT WITH GEAR LEVER IN NEUTRAL POSITION BY PRESSING CLUTCH PEDAL.
- WHILE DRIVING ON ROAD, BRAKE PEDALS SHOULD BE LOCKED TOGETHER, USE SLOW MOVING VEHICLE EMBLEM AND WARNING LIGHTS.
- DO NOT RUN FAST ON ROUGH GROUND, TURNS AND SLOPES TO AVOID JERKS.
- SITTING IS PROHIBITED ON FENDERS IF THERE IS NO SPECIFIC SEAT PROVIDED. DISENGAGE PTO AND STOP ENGINE BEFORE ATTACHING OR DETACHING IMPLEMENTS.
- BEFORE LEAVING THE TRACTOR SEAT, LOWER THE EQUIPMENT, POSITION GEAR LEVER IN NEUTRAL, STOP ENGINE AND APPLY PARKING BRAKE.

4

SERVICE INSTRUCTIONS

1. CLEAN THE PRIMARY FILTER ELEMENT AFTER EVERY 250 HRS OF OPERATION OR IMMEDIATELY WHEN THE RED BAND APPEARS ON THE SERVICE INDICATOR.
2. NEVER REMOVE THE SECONDARY ELEMENT FOR CLEANING. ONLY REMOVE WHEN REPLACEMENT OF IT IS REQUIRED.
3. REPLACE PRIMARY & SECONDARY ELEMENT UPON 3RD CLEANING REQUIREMENT OF THE PRIMARY ELEMENT OR AT 750 HOURS (WHICHEVER OCCURS EARLIER).
4. GENTLY PULL FILTER ELEMENT BACKWARDS TO REMOVE FILTER OUT FROM HOUSING.

⚠ CAUTION:

5. CLEAN PRIMARY ELEMENT ONLY BY TAPPING VERTICALLY ONLY ON CLEAN FLOOR. DON'T TAP DIAGONALLY/AT AN INCLINED ANGLE.
6. SECONDARY ELEMENT SHOULD NOT BE CLEANED OR REMOVED DURING CLEANING OF PRIMARY ELEMENT.
7. USE CLEAN CLOTH TO WIPE SEALING AREAS OF FILTER ELEMENT WITHOUT REMOVING SECONDARY ELEMENT.
8. ENSURE PROPER SEATING OF FILTER INTO HOUSING BEFORE LATCHING THE COVER. DO NOT USE LATCHES ON THE COVER TO FORCE THE FILTER INTO AIR CLEANER WHICH COULD CAUSE DAMAGE TO HOUSING AND WILL VOID THE WARRANTY.
9. THE VACUATOR VALVE SHOULD ALWAYS BE IN PERFECTLY DOWNWARD DIRECTION.



5

WARNING

- PULL ONLY FROM TOW HOOK. PULLING FROM ANY OTHER POINT CAN CAUSE REAR OVERTURN.
- DO NOT OPERATE THE PTO WITHOUT GUARD.
- USE SAFETY CHAIN WHEN TOWING EQUIPMENT

FAILURE TO FOLLOW ANY OF THE ABOVE INSTRUCTIONS, CAN RESULT IN SERIOUS INJURY TO OPERATOR OR OTHER PERSON.

6

WARNING



SEAT BELT MUST BE WORN BECAUSE THIS TRACTOR IS EQUIPPED WITH ROLL OVER PROTECTION.

FAILURE TO FASTEN SEAT BELT COULD RESULT IN SERIOUS INJURY OR DEATH

7

CHAPTER -3 INSTRUMENTS AND CONTROLS

3.1 CONTROLS

NOTE: Consult the Operation chapter for instructions on how to correctly use the controls.



Fig.3.1

3.2 INSTRUMENT PANEL

1. Hour cum RPM meter.
2. Battery charging warning light. (Should go off as soon as the engine starts.)
3. Oil Pressure warning light. (Should go off as soon as the engine starts & oil pressure is within limit.)
4. Water Temp. Gauge
5. Fuel Gauge.
6. Left Turn indicator light.
7. Right Turn indicator light.



Fig.3.2

3.3 HOUR CUM RPM METER

Needle of this meter indicates speed of engine in revolution per minute and the hour meter indicates the number of hours worked by the engine. Green zone is safe for operation.

NOTE: Hour meter may be deferring from actual hour (As per Clock) this is purely depending on Engine RPM.



Fig.3.3

3.4 ENGINE COOLANT TEMPERATURE GAUGE

- Green area = normal operating temperature. Wait for the pointer to reach the green area, indicating the normal operating temperature.
- Red area = temperature too high.

CAUTION: If the needle moves beyond normal range, towards RED zone, follow the procedure:

1. Drive safely to the side of road and stop your tractor. Allow the engine to run idle.
2. If the temperature does not go down, shut it off and allow enough time for it to cool.
3. Visually inspect the fan belt for looseness, breakage and all water hose connections for leak.
4. If the fan belt is OK and no coolant leak is noticed check the coolant level.
5. Add coolant if required otherwise contact your nearest dealer.

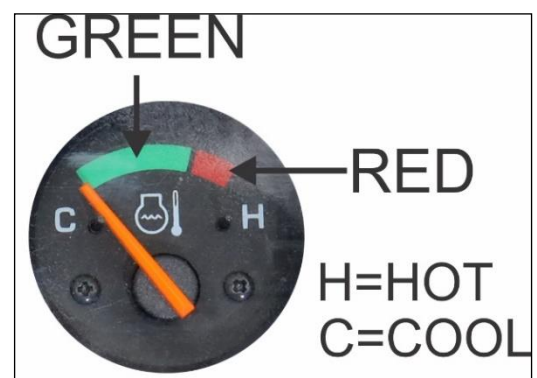

Fig.3.4

3.5 FUEL LEVEL GAUGE

When the pointer moves into the amber zone it shows there are still about 5 liters of fuel in the tank.

Red - Reserve

Amber – Reserve to 1/4

Green –1/4 to full

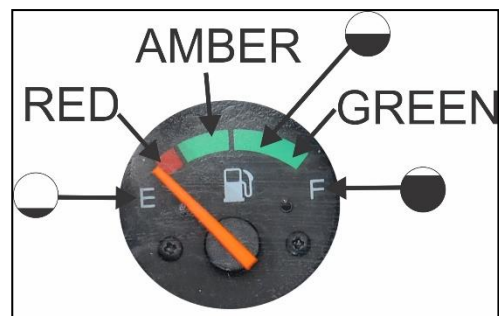

Fig.3.5

3.6 DASHBOARD

1. Led indicator.
2. Combination Switch.
3. Mobile Charging Socket.
4. Ignition key.
5. Hazard Warning Light Switch.
6. Beacon Light Switch (Optional).



Fig.3.6

3.7 COMBINATION SWITCH FOR FOLLOWING OPERATIONS:

Side Indicator Switch (A&B): This switch is used for indicating the vehicle turn. Move turn signal lever left to indicate left (L) hand turn or right (R) for right hand turn. Indicator lights will flash according.

Head Light and Parking Light Switch (C): This switch illuminates all lights (Parking Light, Head Light) with the clockwise rotation.

Horn Switch (D): Press this switch to blow the Horn.

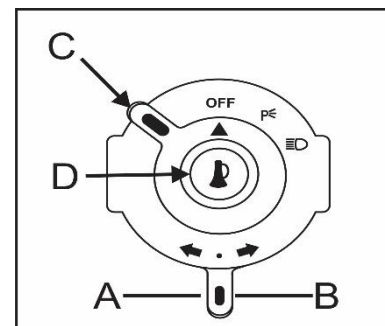
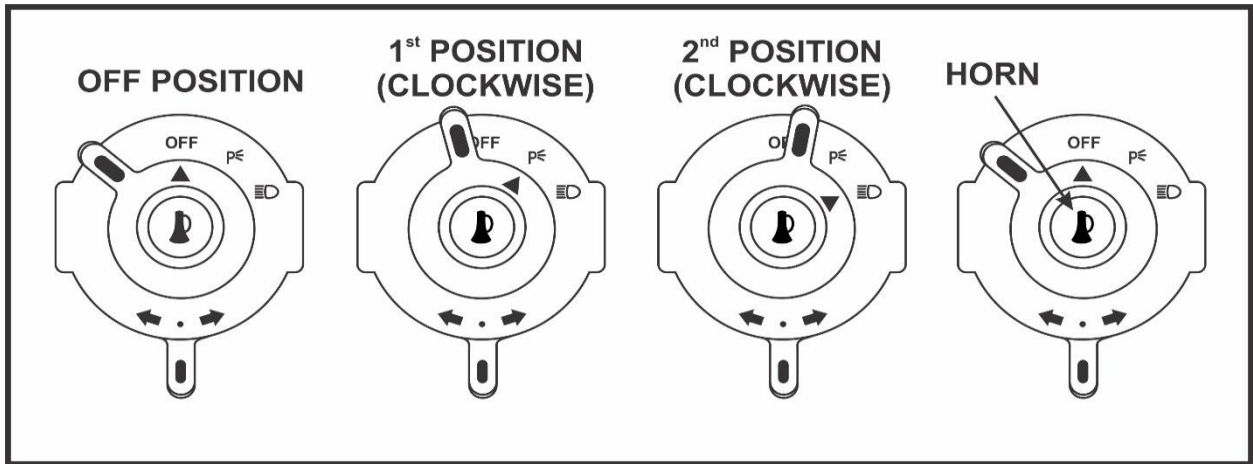

Fig.3.7

OFF Position	1st Position (Clockwise)	2nd Position (Clockwise)	Horn
All lights are off	At 1st point, Parking lights, Instrument panel lights and tail lights will glow.	At 2 nd point, Head lights (Low Beam), Instrument panel lights, Parking lights and taillight will glow.	Press the combination switch to blow the Horn.



3.8 BATTERY CHARGING INDICATOR

This indicator indicates that either battery is being charged or not. Refer the above given observations with respect to different conditions:



Condition			Battery Charging System Functioning
Ignition Switch	Engine	Indicator	
On	Off	Glow	Ok
On	Off	Off	Charging System or Battery is defective, get both things checked from electrician
On	Start/Running	Off	Battery being Charged
On	Start/Running	Glow	Charging System is defective, or Battery is draining out, get the charging system checked from electrician

3.9 DRIVER'S SEAT

While seating, adjust the wt. of operator with wt. adjustment knob provided at back side of seat so as to be comfortable driving & to minimizes vibrations. With the fore & aft adjusting knob, slide the seat so as to have a comfortable approach towards all levers. The range of effort that can be adjusted while sitting on seat is 50-140 kgf.

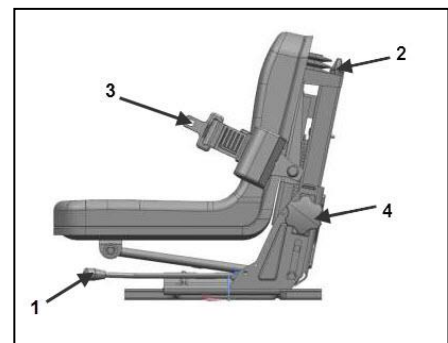

Fig.3.8

Adjustment:

1. lift the lever (1) to move the seat forward and backward.
2. Use knob (2) to adjust the suspension.
3. Use knob (4) to adjust the height of the seat vertically.
4. Seat belt (3) for safety

3.10 TOOLBOX

Toolbox contains a kit of tools for the daily maintenance.

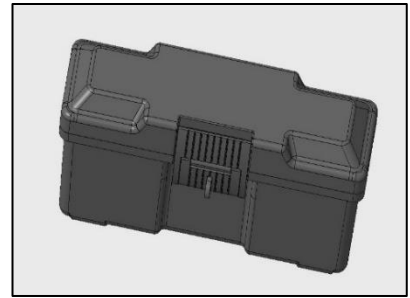

Fig.3.9

3.11 UNDER HOOD MUFFLER

- Under hood muffler with better aesthetics and increased field of vision with better sound muffing capabilities.
- Heat Insulation & sound muffing sheets under the bonnet hood for noise reduction

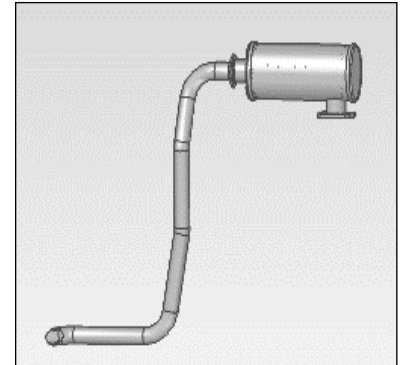
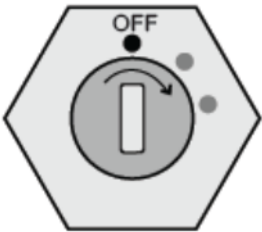
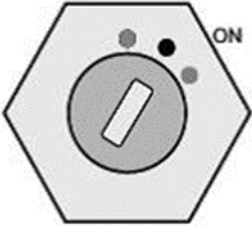
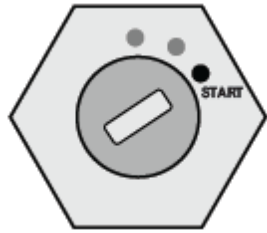

Fig.3.10

3.12 IGNITION KEY

Functioning of starting key switch is as below:

1st Position (OFF):	2nd Position (ON START):	3rd Position (START):
All the electrical systems remain disconnected in this position.	The warning lights (Battery, Oil Pressure indicator) will be functional in this position.	Turn the key further clockwise to start position to start the engine.
		

3.13 HAZARD WARNING LIGHT SWITCH

Purpose of the hazard switch is as follows:

- All the four lights blinking, indicates that driver has no control on tractor.
- Mechanical defects in the tractor.
- Push this switch to blink all indicators in HAZARD situation to alert others



Fig.3.11

3.14 HEAD LIGHTS & TAILLIGHTS

Tractor is equipped with E marked head and taillights.



Fig.3.12



Fig.3.13

3.15 PLOUGH LIGHT

Adjustable plough lamp (A) is provided at rear right side and it is mounted on RH fender.



Fig.3.14

3.16 BATTERY ISOLATOR SWITCH

This switch is used to ON/OFF electric circuit of tractor:



Fig.3.15

CHAPTER -4 OPERATION

4.1 BOARDING THE TRACTOR

Always board the tractor from left hand side where a footrest is provided while taking care the other part of body must not foul with levers. This will provide ease to operator.

4.2 LEAVING THE TRACTOR

After stopping the tractor, leave the tractor from preferably from the LH side of tractor

4.3 STARTING THE ENGINE (IN SAFETY MODE – NEUTRAL POSITION ONLY)

- A** - Check that, the gearshift lever is in neutral position.
- B** - Move the low/medium/high speed selector lever to neutral position.
- C** - Move the PTO lever to neutral position.
- D** - Rotate the ignition key clockwise and release it after the tractor starts.
- E** - Release the hand brake.



MAKE SURE THAT THE STARTING SYSTEM ALLOWS THE ENGINE TO START ONLY WHEN THE LOW/MEDIUM/HIGH SELECTOR LEVER ARE IN THE NEUTRAL POSITION. IF THIS FAILS TO OCCUR, HAVE THE TRACTOR REPAIRED BY YOUR DEALER OR AUTHORIZED SERVICE CENTER.

4.4 COLD WEATHER STARTING (TEMPERATURES BELOW 0°C OR 32°F)

- Perform operations A, B & C as instructed above.
- Turn the ignition key to the "ON" position and keep it there for maximum 5 - 8 seconds.
- Turn the ignition key to the "START" position and start the engine.
- If the engine fails to start within 10 seconds, return the key to the "STOP" position.
- Again, turn the ignition key to the "ON" position and keep it there for maximum 5 - 8 seconds.
- Turn the ignition key to the "START" position and start the engine.

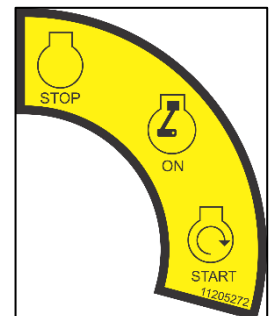

Fig.4.1

NOTE:

- Do not keep the key turned to the start position for more than 5 – 8 seconds at a time.
- Wait at least 1 minute after every two failed attempts of starting the tractor.
- If the engine does not start regularly and easily, do not continue as for you may run down the battery. Bleed any air that may have accumulated in the fuel system and, if the problem persists, check that:

1. The fuel filters are not blocked.
2. The battery and starter motor are efficient/ Working Fine.

3. The fuses of the ignition circuit are in good condition and that the fuel shut-off valve (knob) is open.
 4. Before starting a cold engine in cold weather first cover the radiator with a radiator cover.
 5. Remove the cover as soon as a normal working temperature has been reached.
- If the Problem persists, contact your dealer or a specialized workshop.



When outdoor temperatures drop to around or below 0°C. (32°F), check the cooling system and if necessary, add the recommended antifreeze.



Do not inject fluids (ether) to make the engine easier to start in cold weather. The tractor is equipped with a cold



When the engine is running, keep at a safe distance from the radiator fan.



To prevent accidents, never allow anyone to sit on the mudguards or on any other part of the tractor or implement.

4.5 RUNNING IN

It is essential to take the following precautions during the running in period:

1. Experience has shown that the first 50 hours of use are of fundamental importance for the subsequent performance and working life of the engine.
2. During this period, do not subject the tractor to loads greater than those it will have to deal with during the rest of its working life.
3. It is preferable use the tractor in agricultural operation during this time & material handling work in these first 50 hours.
4. Engage low gears when towing heavy loads.
5. When running in, check regularly that all screws, nuts and bolts are tight.

4.6 AFTER STARTING THE ENGINE:

Before moving off, make sure you are perfectly familiar with the brakes, transmission, PTO, and engine shutoff.

1. Release the parking brake.
2. Look out of bystanders, especially when backing up.
3. Select the gear required and fully release the clutch pedal, & then select the engine speed range.
4. Make sure that the lever is set for the direction required.
5. Move your foot completely off the clutch pedal and slowly accelerate until you have reached the speed you need.

CAUTION: Do not keep your foot on the gearshift clutch pedal when driving and remember to check and adjust the clutch to prolong its life and avoid sudden damage to it.

CAUTION: If your tractor is equipped with a mechanical reverse shuttle, always bring the tractor to a complete standstill before changing direction.

4.7 STOPPING THE TRACTOR:

1. Reduce the engine speed.
2. Depress the gearshift clutch pedal to disengage drive.
3. Once the tractor has come to a stop, move the gear lever and speed range lever to neutral position before releasing the gearshift clutch pedal.
4. Use both pedal brakes to stop the tractor and then apply the parking brakes.
5. However, when you release the pedal, the engine returns to the speed set by the hand lever.
6. When using the accelerator pedal, always set the hand throttle lever to the idling position.

4.8 TURNING OFF THE ENGINE

1. Turn the hand throttle lever to the "idling" position.
2. Stop the engine by turning the ignition key to the STOP position to disconnect all electrical circuits.

4.9 OPENING & CLOSING THE BONNET

1. Firstly, insert the key into the keyhole provided at the front of bonnet as shown in (fig. 4-2) Rotate it clockwise direction.
2. To close the bonnet gently lower the hood down then press it until lock is engaged.
3. The tractor is provided with a set of two keys. If lost contact the authorized dealer to get the lock replaced

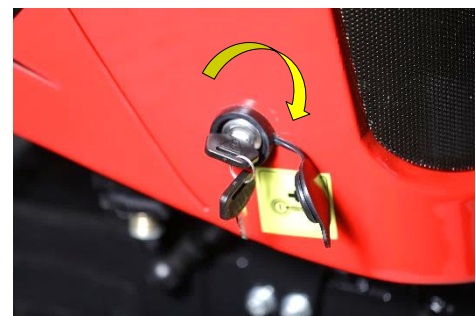

Fig.4.2

4.10 ACCELERATOR PEDAL

The accelerator pedal can override the setting of hand throttle lever to accelerate the engine. However, when you release the pedal, the engine returns to the speed set by the hand lever. When using the accelerator pedal, always set the hand throttle lever to idling position.

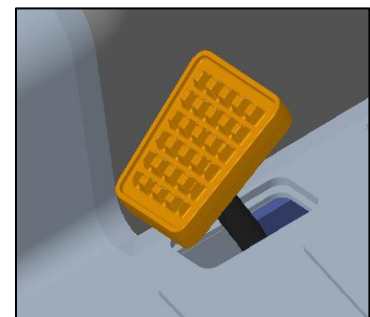

Fig.4.3

4.11 CLUTCH PEDAL

Pedal released = Drive engaged.

Pedal pressed = Drive disengaged.

Select lower gear as per Load condition and don't override the clutch for acceleration



Never keep your foot resting on the clutch pedal when driving



Never coast down slopes with the gear lever in neutral/clutch Pressed when in gear.



Fig.4.4

4.12 GEAR SHIFTER LEVERS

- Gear shifter lever enables to get the required speed (9 Forward and 3 Reverse) by selecting the gear with combination of high-medium low gear lever.
- Before changing the tractor movement from forward to reverse or reserve to forward direction wait for the tractor to come to idling RPM.
- Release accelerator pedal and press the clutch pedal. Select required gear, release the clutch gradually and accelerate the engine.



Fig.4.5



WARNING

When traveling downhill always remain in gear. Never press clutch pedal. The gear selected should be same as used to climb up. For engaging or disengaging gear always use the clutch.

4.13 SHIFTING SPEED RANGE SELECTOR LEVER

This lever is used to change the low speed into high speed or vice versa when tractor is moving. According to requirement you can use it with combination with main gear lever. Select the speed before tractor movement.

Speed Selection:

1. Neutral Position: Lever in the middle cut.
2. Medium Speed: Move the lever out of the cut and shift towards front end.
3. High Speed: Move the lever out of the cut and shift towards front end.
4. Slow Speed: Move the lever out of cut and shift towards rear end.

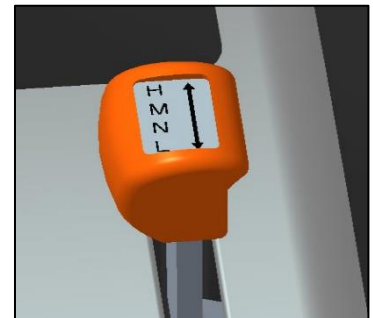

Fig.4.6

4.14 LEVER (2WD / 4WD)

The lever has two positions viz. forward 4WD and backward 2WD on the tractor.

In (fig.4-7). The purpose of the front drive is to increase traction on uneven ground, mud and slippery surfaces etc. The control lever is used to engage and disengage the front drive. Both maneuvers can be carried out whilst the tractor is driving in a straight line and never under stress.



Fig.4.7

NOTE: Only use four-wheel drive when strictly necessary. Avoid use of 4WD when maximum traction is not required, e.g. on hard ground, roads, etc., since this would only increase tyre wear unnecessarily.

Always leave the 4WD lever engaged when parking on slopes with the trailer connected.



WARNING

Never use the 4WD engaged while driving at higher speeds. Always use only when high traction is required.

4.15 PTO (POWER TAKE OFF) lever

- The tractor is equipped with a Direct power take off that complies with international regulations.
- It is installed at the rear of the transmission housing.
- PTO shaft has standard 6 Spline. PTO can be engaged or disengaged by PTO shifter lever.
- Two speeds can be obtained by putting the PTO Lever in 2 different position (i.e.540 and 1000).

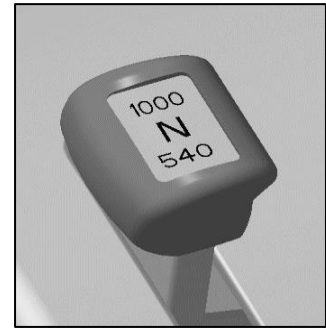

Fig.4.8

Lever Position	PTO Speed	Engine RPM
540	540	2300
N	-	-
1000	1000	2305

4.16 PRECAUTIONS WHEN USING THE PTO

PTO shafts and implements operated by means of the PTO can be extremely dangerous. It is therefore advisable to comply with the following important instructions:

1. NEVER operate without the PTO cover (Fig.4-9). These parts protect Persons from injuries and the shaft splines from damage.
2. Before connecting adjusting or working on implements operated by the PTO, disengage the PTO, stop the engine, remove the key from the dashboard and engage the parking brake.
3. Do not work under raised implements.
4. Check to make sure that all implements operated by the PTO are fitted with the correct protections, are in a good condition and comply with the provisions established by law.
5. Before driving an implement through the PTO, ALWAYS make sure that all bystanders are well away from the tractor.
6. Fix the drawbar in the central position when using implements that are driven by the PTO of the tractor.
7. When using the PTO drive with a stationary tractor, ALWAYS make sure that the gears are in neutral and that the parking brake is applied.
8. Before starting up any PTO- driven implement hitched to the three-point linkage, lift the implement to its full height using position control and check that at least 1/4 of the total length of the telescopic section of the drive shaft is engaged.



Fig.4.9

4.17 A REQUIREMENT TO USE ONLY POWER TAKE-OFF DRIVE SHAFTS WITH ADEQUATE GUARDS

1. Remove PTO cap only when the PTO is to be used.
2. As soon as PTO-driven implement is removed, re-install cap over PTO stub shaft again after wards.
3. There are various versions of PTO guard that are not shown here.
4. Never operate PTO unless the master shield is in the position shown.
5. Switch off the PTO before raising the implement.
6. Before using the PTO, the maximum permissible angle of articulation on the telescoping driveline must be ascertained.
7. During operation, there must be no contact between the PTO guard and the telescoping driveline.
8. This is particularly important when turning corners.
9. Always put a guard on the telescoping driveline and take action to prevent it from turning with the shaft.
10. Do not operate the telescoping driveline unless a guard is installed that covers the PTO shaft completely and does not turn with the shaft.
11. Stay clear from the area of the three-point linkage when controlling it.
12. The mounted machinery must be lowered on the ground before leaving the tractor.
13. Stay clear from the area between tractor and trailed vehicle.



Fig.4.10

4.18 INFORMATION ABOUT USING IMPLEMENTS WITH PTO DRIVE SHAFTS

1. Shut off engine and disengage PTO before attaching PTO-driven equipment.
2. Attach implement to tractor before connecting PTO drive line.
3. Lock TPL in upward position if it is not to be used. Rotate PTO shield upward for clearance.
4. With engine off, turn shaft slightly by hand if necessary, to line up splines.
5. Connect drive line to PTO shaft. Pull out on shaft to be sure drive line is locked to PTO shaft.
6. Place PTO shield in downward position. Be sure all shields are in place and in good condition.
7. Never operate PTO unless master shield is properly installed.
8. WITH ENGINE STOPPED, check integral Shields on drive line by making sure they rotate freely on Shaft.
9. Lubricate or repair as necessary. Check carefully for any interference, make sure TPL is locked in the upward position if it is not used.
10. As far as possible, angles (a) and (b) at the universal joints should be the same at both ends of the telescoping driveline.
11. In applications where this is not the case (e.g. sharp turns with PTO engaged), it is recommended to use a continuous velocity drive shaft.

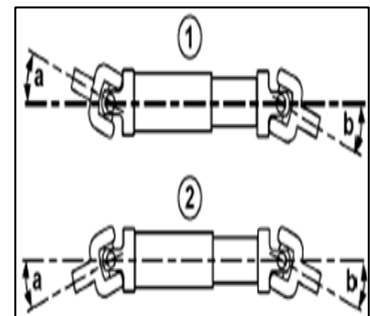

Fig.4.11 Articulation of Telescoping Driveline

NOTE:

- The two schematic drawings do not show any guards on the telescoping driveline.
- A guard is mandatory when using telescoping drivelines.
- Only operating conditions described in the Operator's Manuals of the various implements are permitted.
- This applies particularly to maximum permissible angle of Articulation, to the use of freewheel clutches and overload Clutches, and to the prescribed amount of overlap when Shaped pipes are pushed together.
- Before using a PTO-driven implement, take action to ensure that the telescoping driveline is lubricated regularly.
- Comply with instructions in the Operator's Manual provided by the manufacturer.
- On multi-component telescoping drivelines, the yokes at each end must be aligned as shown.
- The yokes at each end must NOT be at 90° to one another.

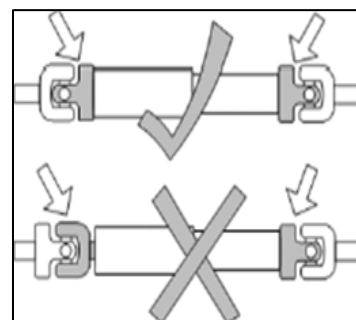

Fig.4.12 Align Forks
Correctly
1: Z - Shaped layout
2: W - Shaped layout

4.19 HAND THROTTLE LEVER

Hand throttle lever mounted on front panel is used in field application. To increase the speed of engine, pull the lever towards the driver and to decrease, push it away.



Fig.4.13

4.20 HYDRAULIC COUPLING DEVICES

Remove the dust cover from coupler (A). When connecting the hose, ensure that the connectors are perfectly clean. Connect the trailer's pipe with the QRC's, operate the DCV lever respectively to lift trailer.



Fig.4.14

4.21 POWER STEERING

The tractor is equipped with power steering with a pump of 5.5cc & steering unit of 50cc which enables the operator for ease in operation.

The power steering function goes off when the engine is shut off.

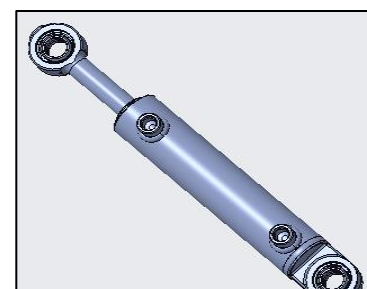

Fig.4.15

4.22 POWER STEERING CIRCUIT DIAGRAM

Sr. No.	Name of Pipe	Color
1	Pressure Pipe	Red
2	Suction Pipe	Yellow
3	Return Pipe	Blue

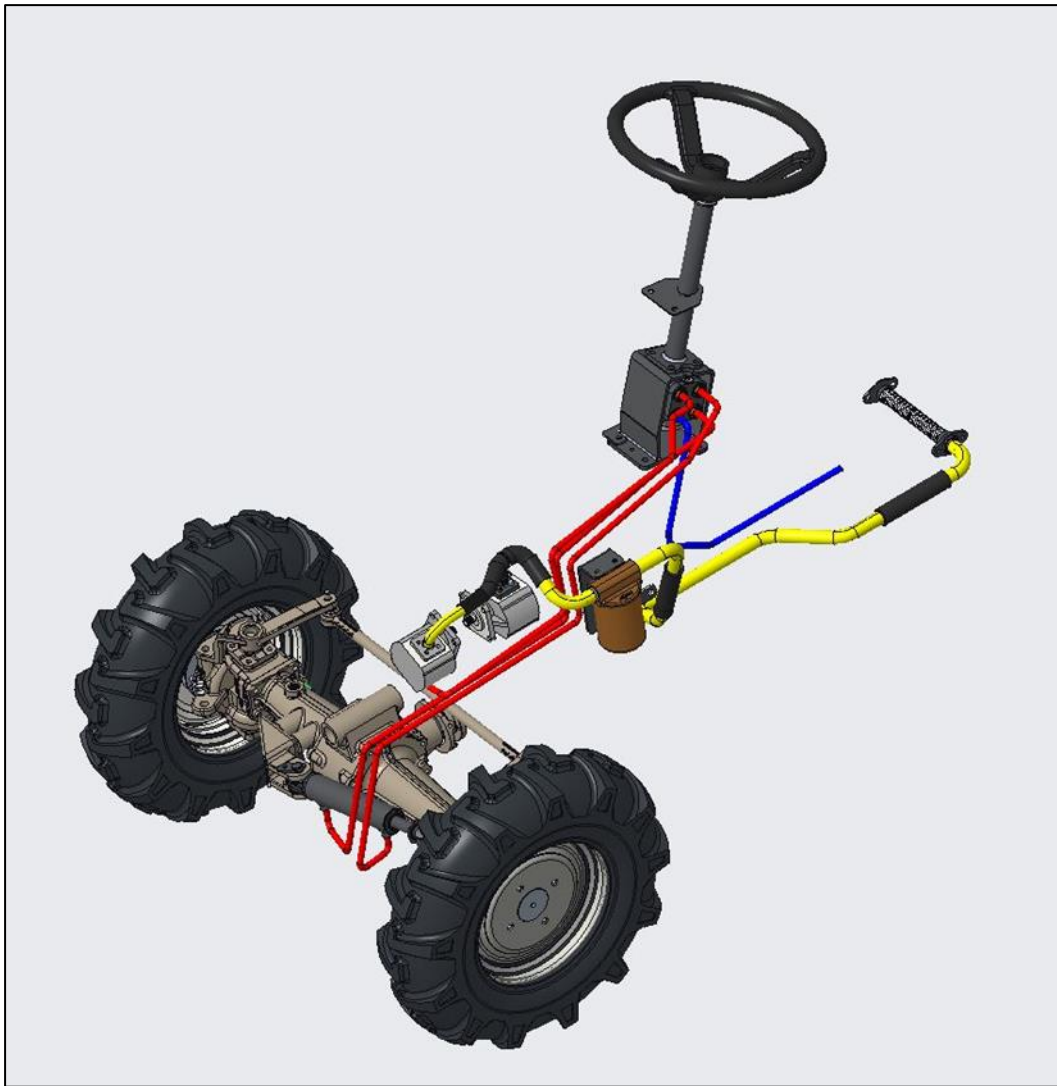

Fig.4.16

4.23 TRANSPORT LOCK

- It acts as safety device during transportation of implements.
- It is located on front side of hydraulic system below driver seat for that you need to open TCA window.
- For uses the transport lock, fully tighten the response valve by rotating it in clockwise direction.
- Stay Response Valve should always be closed during implements transportation.

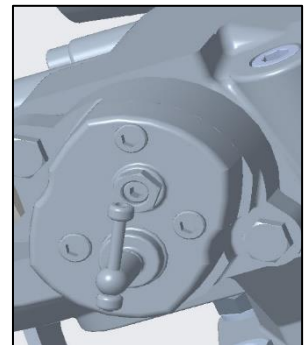

Fig.4.17

4.24 DIFFERENTIAL LOCK

- When you press the differential lock pedal, both the rear wheels will rotate at same speed.
- Differential lock operation should be done with front tyres in straight position only. Differential lock should be disengaged at turnings to avoid any damage of differential assembly.
- Do not apply differential lock while tractor speed is more than 6 km/hour or on turning.



Fig.4.18

4.25 SERVICE BRAKE

The main brakes are operated by means of two pedals, one for each rear wheel. Braking on one side assists steering in tight maneuvers. By locking rear wheel on the inside of curve, you can virtually turn the tractor around on its own axis. For simultaneous braking during normal use and for on road use, simply lock the two pedals together with the special brake coupling lock.



Fig.4.19



WARNING



WARNING

ALWAYS KEEP THE BRAKE PEDALS COUPLED FOR ON-ROAD DRIVING TO ENSURE SIMULTANEOUS BRAKING ON BOTH REAR WHEELS. NEVER USE THE BRAKES INDEPENDENTLY WHEN DRIVING ON PUBLIC ROADS. IF YOU EVER NOTICE THE BRAKES BECOMING LESS EFFECTIVE, IDENTIFY THE CAUSE IMMEDIATELY AND REPAIR. WHEN WORKING ON SLOPES AVOID USING THE BRAKES AS MUCH AS POSSIBLE AND SELECT A LOWER GEAR IN ORDER TO USE ENGINE BRAKING.

4.26 PARKING BRAKE

- Pull the lever completely to operate the parking Brake.
- If this is not the case, pull the parking brake lever with higher force.
- The indicator light in the instalment panel lights up when the parking brake is engaged, independently of the force used for the engagement.
- Before starting the tractor, shift into gear and release the parking brake.

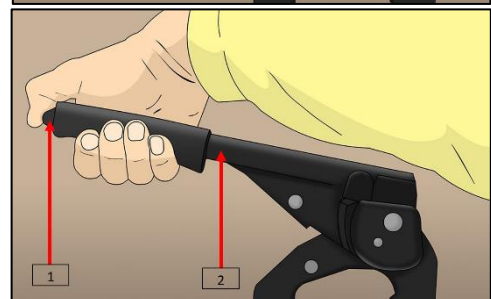
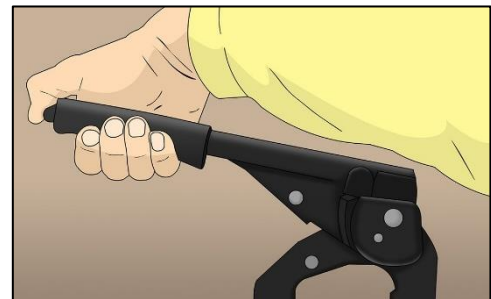

Fig.4.20

4.27 PARKING BRAKE RELEASE

- Press the brake pedal slightly, push button(1) inwards, let the Parking brake lever (2) down and release it.
- Always engage the hand brake when the tractor is used for work at a standstill (Stationary Position), even if only for brief periods of time.
- Driving the tractor with the parking brake partially engaged will cause damage to internal transmission components.
- Make sure the brake is fully off.

4.28 USE IN PADDY FIELDS

When using the tractor in water-logged soil or in paddy fields where the water level could rise above the height of the PTO shaft, ask your dealer for instructions on all necessary waterproofing and sealing measures. If such measures are not taken, the warranty could be rendered invalid.

4.29 GROUND SPEED TABLES

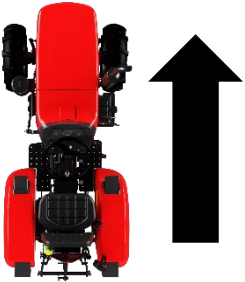
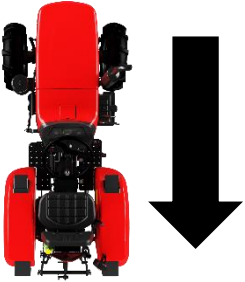
GROUND SPEED TABLES @ RATED ENGINE RPM (STARTRAC 263 4WD)				
	SHUTTLE OPTION	RANGE	GEAR	REAR TYRE SIZE
				(Agri Tyre) 8.3 X 20
FORWARD GEARS		LOW	1	1.43
		LOW	2	2.74
		LOW	3	4.98
		MEDIUM	1	4.68
		MEDIUM	2	8.96
		MEDIUM	3	16.30
		HIGH	1	6.16
		HIGH	2	11.79
		HIGH	3	21.45
REVERSE GEARS		LOW	R	2.05
		MEDIUM	R	6.72
		HIGH	R	8.85

*speed may vary according to tyre combination /Type /Size.

*Following listed gear speeds are in km/hr.

*Above speeds can vary within ± 5 % according to tyre pressure & loading conditions.

4.30 WHEELS AND TYRES

- Tyre play vital role in transportation and agriculture operations.
- It is the most important factor in the efficient performance of tractor it should be used only as per company recommendation.
- Here we will discuss only pneumatic tyre.
- Regularly check that the front and rear wheel nuts are fully tightened.
- Torque as per specification: Rear wheel is 210 Nm and front wheel is 110 Nm.
- Tyre pressure must be checked and adjusted before using the tractor. Make further checks at regular intervals.
- Tractors are supplied by the manufacturer with tires inflated at higher pressures than recommended.
- The pressure should be adjusted afterwards by the user according to values given in the tables of tire manufacturers and to the use anticipated for the tractor.
- If these simple rules are carefully followed, they will ensure maximum working life for your tires.
- If you notice any cuts in the tread or side walls, have them vulcanized immediately to avoid further damage to the tires.
- Avoid parking the tractor on floors which are covered with oil or diesel fuel. Also avoid parking the tractor where the tires are permanently exposed to direct sunlight, especially if the tractor is not going to be used for some time.

In general, tractor is considered for two types of work:

- Work on soft soil where maximum adhesion is needed. In this case there will be use of lowest pressure compatible with the load carried.
- Work on hard ground and roads, towing etc. In this case there will be use of maximum pressure.

4.31 TYRE PRESSURE IN FIELD OPERATIONS

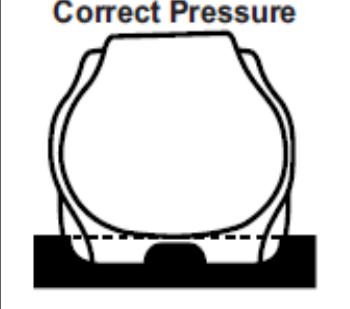
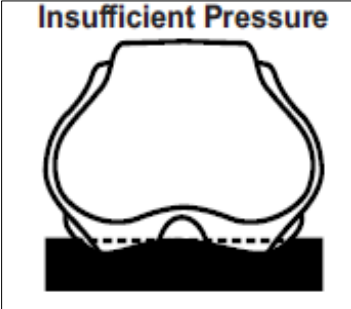
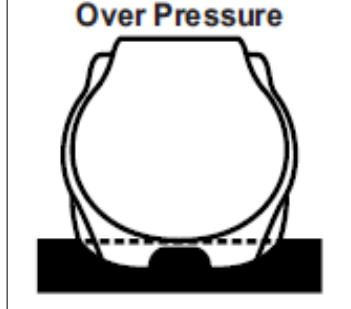
<p>Correct Pressure</p> 	<p>Insufficient Pressure</p> 	<p>Over Pressure</p> 
<p>Good adherence by dirt grousers.</p>	<p>Reduce adherence through lack of tyre grip.</p>	<p>Reduce group due to lack of Cleaning</p>
<p>Good cleaning of the tread</p>	<p>Deterioration of tyre casing by traction forces.</p>	<p>Deterioration due to compacted ground.</p>

4.32 TYRE PRESSURE IN ROAD OPERATIONS

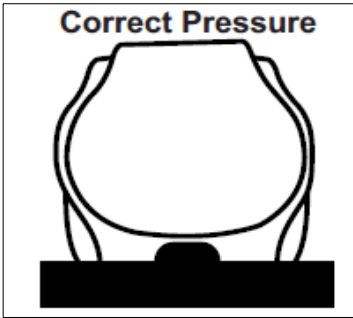
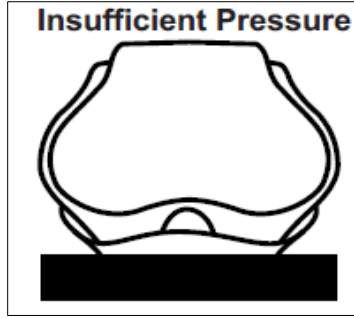
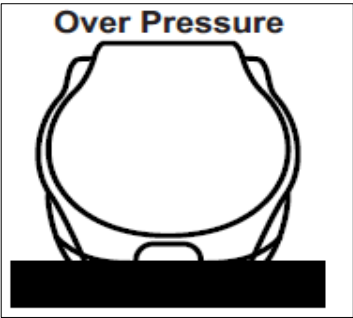
 <p>Correct Pressure</p>	 <p>Insufficient Pressure</p>	 <p>Over Pressure</p>
Resistance to Wear	Reduce adherence through lack of tyre grip.	Reduce grip due to lack of Cleaning
	Deterioration of tyre casing by traction forces.	Deterioration due to compacted ground.

Drive slowly on roads if the pressure in the tires has been reduced for use on soft earth. To obtain maximum efficiency, do not use tires with more than 30-50% wear.



When jacking up the tractor, pay attention that its weight is correctly distributed and Securely wedge the wheels on the ground. Tighten all nuts and bolts to the required torque.

4.33 TYRE BALLASTING

- Proper ballasting is an important factor in tractor performance.
- For better performance of tractor, the weight of tractor can be decreased as per requirement.
- Maximum productivity can be achieved only if tractor weight is appropriate for the job.
- Ballast is required for traction and stability.
- The tractor is equipped with detachable front toe hook.
- Use the front toe hook to tow the tractor.

Following factors determine amount of ballast.

- Soil surface loose or firm
- Type of implement
- Travel speed and tractor power output partial or full load.

4.34 MECHANICALLY CONTROLLED POWER LIFT – HYDRAULIC SYSTEM

In this tractor live hydraulic system is provided in which hydraulic pump is driven by engine and mounted at cover of engine. As the engine run, the hydraulic pump also starts working and the oil is transferred from pump to lift via hydraulic pump (located at LH side of Engine). Transmission lubrication oil is used as hydraulic oil.

The power-lift control levers are used to set the following modes

- Position lever (Black Color)
- Draft lever (Orange Color)

Each of these modes must be chosen according to the type of work in hand, the type of implement and the consistency of the soil.

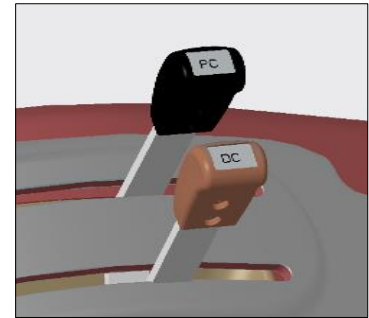

Fig.4.21

4.35 POSITION CONTROL (PC) LEVER

- Position control is used to raise hold and lower three-point linkage for mounted Implements during tillage/field operation which works above the ground.
- Once the height of implement is set, position lever maintains it.
- Always use Position lever for transporting the implement.
- One adjustable locking knob is provided for maintaining the specific position.

4.36 DRAFT CONTROL (DC) LEVER

- Automatic Draft Control is designed to respond at the time of sudden resistance Faced by the mounted dragging type implements while working in the field.
- Keep both position and draft Lever (Black & Orange) in lower most position (implement grounded). Now move the draft lever (Orange) towards upside position on sector as implement starts rising move back the lever by few mm.
- **Proper Setting of Draft Prevents:** Overloading of engine, breakage of implements, clutch Slippage, tyre slippage, and excess fuel consumption.

4.37 THREE-POINT LINKAGE

Three-point linkage is used to mount the implement, which is fully mounted, or semi-mounted and used for different field operation. Three-point linkage is controlled by hydraulic lever. In these two lower links are available, of which one side of the lower link is attached with differential housing and other is used to hitch the lower pin of the implement. Lift rods are mounted on lift arm that is operated through rockshaft. Loose side of Top link is used for attaching upper hitch pin of implement. Top link is adjustable for proper setting of implement and ease at the timing of joining.

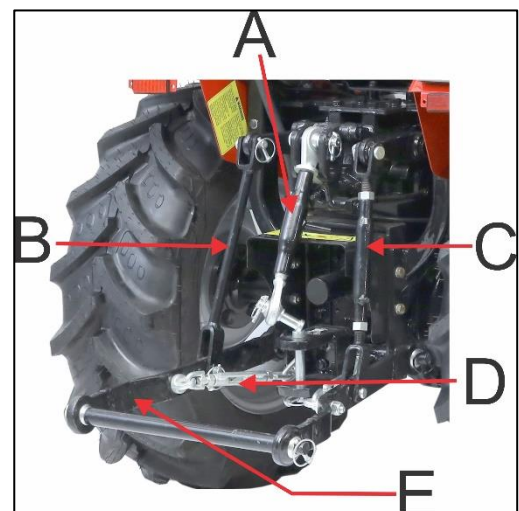

Fig.4.22

4.38 ADJUSTABLE TOP LINK

1. The ADJUSTABLE TOP LINK (A) is supported by a bracket with Two fixing holes.
2. The correct hole to use depends on the height of the implement.
3. For length adjustment of top link, fix the top link other end and turn the lever for increasing or decreasing the length.
4. Adjust the length of the top link to vary the attachment angle of the implement in relation to the ground.

-
5. Shorten the top link to increase the angle of attachment. Lengthen it to reduce the angle of attachment.
 6. The top link has three holes for hitching the implement and adjusting its slant.
 7. It also provides a means of adjusting draft control sensitivity, which should be chosen according to the type of implement used
 - A. Fix top link to the lower hole for greater sensitivity (1)
 - B. Fix the top link to the upper hole for less sensitivity or if jerking is observed.

4.39 ADJUSTABLE LIFT ROD OR LEVELING ROD

- In Fig. 4.22 (B) is FIXED LIFT ROD and (C) is the ADJUSTABLE LIFT RODS. It can be adjusted mechanically or Hydraulically, depending on the lifting, to make the lower links level and lined up with each other.
- This will depend on the type of implement being used and the work to be done.

4.40 LATERAL STABILIZERS CHAIN

- The LATERAL STABILIZERS CHAIN (D) can be set to reduce lateral movement of the lower links if the three-point linkage contacts with graders, rollers, holes, weeder etc.,
- Adjust the stabilizers to restrict the side swing of the lower links.
- When transporting implements that are mounted on the three-point linkage, lateral swing must be eliminated by tightening the stabilizers.
- To adjust the stabilizers chain, turn clockwise/ anti-clockwise to increase or reduce lateral swing.

NOTE: When an implement is raised to on-road transport position, lateral swing of the three-point linkage must be reduced.

4.41 LOWER LINKS

- LOWER LINKS (E) with CAT 1 fixed ball ends.
- Adjusting the RH and LH vertical lift rods.
- The two vertical lift rods can be adjusted by means of adjuster arms in order to alter the lateral angle of the implements.
- The latter position must be used for implements that require a certain freedom of movement (cultivators, spreaders, harrows, ploughs).

4.42 HITCHING IMPLEMENTS

1. Lower the three-point linkage.
2. Adjust the lateral stabilizer to let the lower links swing freely.
3. Ensure there is no person or object between the tractor and Implement.
4. Reverse the tractor on the implement.
5. Raise the three-point linkage until the hooks on the lower links fasten on to the ball ends on the implement crossbar and secure them with safety clips.
6. Adjust the stabilizers to give the right amount of lateral swing for the implement.
7. Hitch up and adjust the top link.
8. Use horizontal adjustment for locking the lower links and for adequate sensing.
9. Also use the float mode. while hitching the implements for ease in hitching

4.43 UNHITCHING IMPLEMENTS

1. Lower the implement to the ground.
2. Adjust the stabilizers to give the correct freedom of movement to the lower links.
3. Remove the safety clips and unhitch the implement's crossbar from the hooks on the lower links.
4. Use float position for adjusting the use in vertical position if certain degree of freedom is required for trail type implements.



ALWAYS STOP THE ENGINE BEFORE ATTEMPTING TO ADJUST THE THREE-POINT LINKAGE OR ANY IMPLEMENT HITCHED TO IT.



ALWAYS SELECT POSITION CONTROL MODE WHEN TRANSPORTING MOUNTED IMPLEMENTS ON THE THREE-POINT LINKAGE. LOCK THE IMPLEMENT INTO TRANSPORT POSITION.



ALWAYS SELECT POSITION CONTROL MODE WHEN HITCHING OR UNHITCHING AN IMPLEMENT TO THE THREE-POINT LINKAGE.



BEFORE GETTING OFF THE TRACTOR, ALWAYS LOWER TO THE GROUND ANY IMPLEMENT THAT IS MOUNTED ON THE THREE-POINT LINKAGE.



NEVER WORK UNDERNEATH AN IMPLEMENT HELD UP ONLY BY THE HYDRAULIC POWER LIFT AND THREE-POINT LINKAGE. SUPPORT THE IMPLEMENT FOR SAFETY AND STOP THE TRACTOR ENGINE



NEVER TOW WITH THE TOP LINK CONNECTED TO THE SWINGING SUPPORT OF THE HYDRAULIC POWER LIFT

4.44 HOW TO SAFELY DRIVE THE TRACTOR

- To drive the tractor, you will need to exercise greater effort if the engine is at standstill.
- Slow and stop the tractor with the brake pedals latched together.
- Tow or push the tractor at moderate speed.
- Affix the SMV sign (SMV – slow moving Vehicle).
- Use the beacon and hazard lights (As per recommendation countries).
- Strictly comply with the laws in force in the country where the tractor is used.

4.45 TRANSPORT THE TRACTOR

- The tractor must be transported with a suitable vehicle.
- Engage the parking brake. Firmly fasten the tractor to the transport vehicle using suitable chains or straps.
- Use the tow bar or its supports as rear fixing points for the tractor.

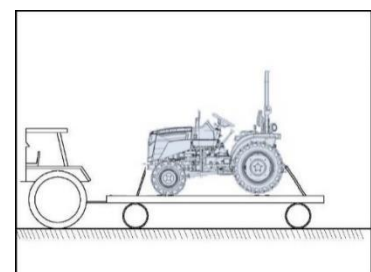

Fig.4.23

CHAPTER -5 MAINTENANCE

5.1 MAINTENANCE SCHEDULE

Observe the following maintenance schedule. This maintenance schedule is applied to tractors which are operated under normal conditions. When your tractor is frequently operated in muddy places, greasing must be carried out more frequently and when the tractor is often operated in dusty places, clean the air cleaner element and fuel filter more frequently. Extra servicing must be carried out according to situation.

Parameters	50 HMR	250 HMR	500 HMR	750 HMR	1000 HMR
GENERAL					
Washing	W	W	W	W	W
Greasing	G	G	G	G	G
Re-Tighten All Fastener	CT	CT	CT	CT	CT
ENGINE					
Engine Oil	R	R	R	R	R
Engine Oil Filter	R	R	R	R	R
Tappet Clearance	CA	CA	CA	CA	CA
Fuel Filter Element	R	R	R	R	R
Fan Belt Tension	CT	CT	CT	CT	CT
Radiator Coolant Level	C	C	C	C	C
Air Filter Element	CL	CL	CL	CL	CL
Fuel Strainer Filter	R	R	R	R	R
CLUTCH					
Clutch Pedal Free Play	CA	CA	CA	CA	CA
TRANSMISSION / HYDRAULIC					
Transmission Oil	C	C	R	C	C
Working of Hydraulic Assembly	C	C	C	C	C
Suction Strainer	CL	CL	CL	RR	CL
Suction Filter	R	R	R	R	R
BRAKES					
Working of Brakes	C	C	C	C	C
Brake Pedal Free Play	CA	CA	CA	CA	CA
STEERING					
Steering Operation	C	C	C	C	C
FRONT AXLE 4 X 4					
Front Differential Oil	C	C	C	R	R
Breather Assembly	CL	CL	CL	CL	CL
WHEEL AND TYRE					
Front Wheel Bolts	CT	CT	CT	CT	CT
Rear Wheel Bolts	CT	CT	CT	CT	CT
Tyre Air Pressure	CA	CA	CA	CA	CA
BATTERY					
Battery Electrolyte Level	C	C	C	C	C
Battery Terminals	C	C	C	C	C

ELECTRIAL					
Working of Gauge & Meters	C	C	C	C	C
Working of Starter & Alternator	C	C	C	C	C
* Engine Oil Change Replacement - First change at 50 HOURS or 3 Months Whichever occurs earlier. Thereafter every 250 Hours or 6 months, whichever occurs earlier.					
* Transmission and Axle Oil Change Replacement - First change at 500 HOURS or 6 Months Whichever occurs earlier. Thereafter every 1000 HOURS or 1 Year, whichever occurs earlier.					

R – Replace	C – Check
RR – Replace If Required	CA – Check & Adjust
CL – Clean	CT – Check and Tighten
Beyond 1000 hrs. repeat the cycle every 250 hrs.	

- Engine oil grade should be selected as per operating temperature condition.
- Anti-freeze should be used in subzero ambient temperature.
- Clean air cleaner element as and when required as per field condition.
- Clutch pedal play should be adjusted as per field operating conditions.
- Read and comply with all the safety precautions in the tractor maintenance part of the Safety Notes Section.
- Old fluid and used filters must be disposed of in the correct way.
- Do not carry out inspections, maintenance work or adjustments on the tractor while the engine is running.

5.2 SEALED UNITS

Do not remove the seals from the following parts: injection pump and over speed screw. If you need to repair or adjust any of these units, contact your local dealer or authorized repair shop. The warranty is automatically invalidated if these seals are tampered with.

5.3 RUNNING IN

- Fade-free efficiency and a long working life largely depend on how the new tractor is treated during the running in period.
- It is therefore extremely important to follow these instructions:
 - A. Your engine does not require any special running in when new.
 - B. You can use it at full power from the start, but you must never overload it.
 - C. Avoid using the engine at full power before it reaches an operating temperature of at least 60°C (140° F).
 - D. Avoid idling the engine for long periods.
 - E. Regularly check for oil leaks.

5.4 HOW TO PREVENT POLLUTION

- To prevent pollution when oil, filters and so forth are changed, always clean the zone around fill, level and drain plugs, dipsticks and filters.
- Before connecting the auxiliary cylinders, make sure that the oil they contain is clean, that it has not deteriorated owing to long storage and that it is of the prescribed type.

5.5 SERVING INTERVALS

- The intervals suggested in the lubrication and maintenance table are indications to use when the tractor is used in normal conditions.
- These intervals should be adapted to the real environmental and operational conditions.
- Servicing must be more frequent in adverse work conditions (in the presence of humidity, mud, sand, very dusty environments).
- If carried out at the prescribed intervals, the operations described in this section will ensure that the tractor operates in a regular way.
- However, remember to carry out the inspections and adjustments (of variable frequency depending on the environmental conditions and type of work carried out) according to your discretion and experience.

5.6 MISCELLANEOUS INSPECTIONS

Periodically check the following components. If faults are discovered, contact your Dealer's specialized personnel and have the damaged parts replaced if necessary:

- A. Hand brake lever: make sure that the ratchet locking mechanism is secure and reliable.
- B. Make sure that all nuts are well tightened.
- C. Make sure that the safety frame bolts are well tightened.
- D. Make sure that all other nuts and bolts are well tightened.

5.7 FUEL INJECTION PUMP

- Only OEM Authorized dealer / your Dealer's specialized personnel may be allowed to work on the injection pump during the warranty period.
- Removal of the seals from the pump will relieve the manufacturer from all and every liability in relation to warranty coverage.

5.8 KEEP THE ENVIRONMENT CLEAN

- When you need to fill the fuel tank or charge the lubricating oil, never forget to position a vessel under the component in question in order to collect any fuel or oil that spills out.
- These products are polluting, so it is very important to protect the environment in this way.

5.9 ENGINE COOLING SYSTEM

- It is advisable to replace the fluid in the system at least once a year even if you have not reached 1000 hours service in total.

5.10 RADIATOR

- To ensure that the cooling circuit operates in a perfect way, it is important to prevent the radiator fins from becoming clogged.
- These fins should be cleaned often, even several times a day if the place of work is particularly dusty.

5.11 LUBRICATION

- Before lubricating any parts provided with grease nipples, carefully clean the fittings surfaces and be sure that their seal ball moves freely.
- After the lubrication, remove any trace of grease to avoid collecting dirt or dust.

5.12 INDICATOR LIGHTS

- Your tractor is equipped with indicator lights that the conditions of your machine.
- Some of these indicate faults, so act promptly if they come on during turning or based conditions.

5.13 FUEL TANK FILLING

Comply with the following instructions when working with the diesel fuel:

1. Do not smoke while filling the fuel tank because diesel is explosive liquid and catch fire easily.
2. Never use such mixtures. Moreover, mixtures of diesel fuel and alcohol are not approved since the resulting lubrication of the fuel injection system is insufficient.
3. Clean around the plug where the fuel is poured and keep it clean.
4. Fill the tank at the end of the day to prevent the formation of overnight condensation.
5. Never remove the plug or fuel the tractor while the engine is running. Keep control of the pump nozzle whilst the tank is being filled.
6. The tank must not be filled. Allow space for an increase in volume. If the original tank plug is lost, it must be replaced with an original spare which must be fully tightened.
7. Dry up any fuel spill immediately.

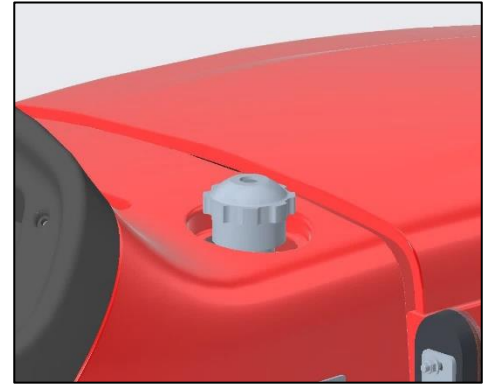

Fig.5.1 Diesel Tank Cap for Filling Diesel

5.14 FUEL REQUISITES

- It is important to use good quality fuel if the engine is to be long-lasting and give a good performance.
- The fuels must be clean, well refined and non-corrosive for the fuel system components.
- Make sure that you use fuel of a known quality and reliable origin.

5.15 FUELING

- Before you fuel the tractor, clean the zone around the fill plug to prevent foreign bodies from entering the tank.
- After fueling, screw on the plug and tighten it well.

5.16 FUEL STORAGE

- Take all the necessary precautions to ensure that stored fuel does not become polluted with dirt, water or other substances.
- Store fuel in black iron cans. Do not store it in galvanized cans as the galvanization treatment would react with the fuel and form compounds that would spoil the injection pump and injectors.
- Store fuel cans away from direct sunlight and slightly tilted, so that any sediment inside is eliminated through the outlet tube
- To make sludge and condensation water easier to remove; there should be a discharge plug C in the lowest point, on the opposite side to the drain tube.

- If the fuel is not filtered from the storage can, use a funnel with the fine gauge mesh over the tracking fuel tank fill plug inlet when fueling.
- Plan your fuel purchases so that summer fuels are not kept for too long and used in the winter.
- Setting up a tank for fuel storage and decanting
 - A. Slope 25%
 - B. Condensation water
 - C. Sludge drain

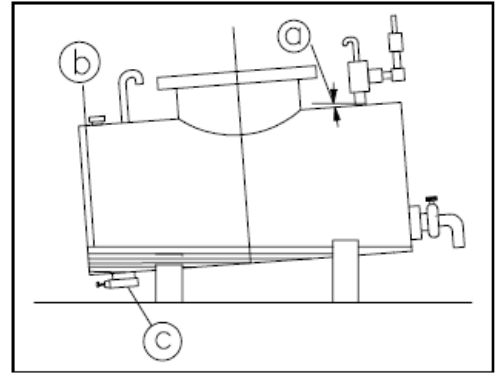

Fig.5.2

5.17 ENGINE OIL LEVEL

- Leave the tractor parked on a flat surface for at least five minutes before checking the level, to allow the oil to settle in the sump.
- Take out the dipstick, wipe it with a rag and then dip it into sump again, then remove the dipstick again and ensure that the oil level is within the H/L mark reaches and does not exceed the level marked on it.
- If necessary, add recommended engine oil through the filter until the required level has been reached.
- Never ever use the engine with the oil level below the "L" Mark.
- We recommend SAE15W40 grade of Engine Oil.

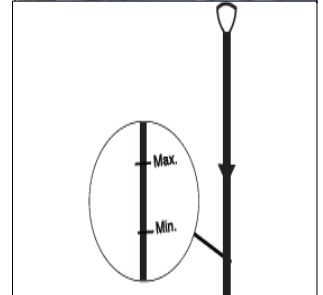

Fig.5.3

5.18 RECOMMENDED ENGINE OIL VISCOSITY ACCORDING TO AIR TEMPERATURE

Temp. (°C)	-30	-20	-10	0	10	20	30	40	50
Engine Oil Viscosity	SAE10W		SAE30			SAE40W		SAE15W-40	

5.19 REAR TRANSMISSION, AND HYDRAULIC OIL LEVEL

- Allow the oil to settle in the transmission and rear final drives before checking the level.
- The oil level in the transmission must be over the midline between the minimum and maximum marks of the dipstick (Fig.5-4) with the lift link in the up position.

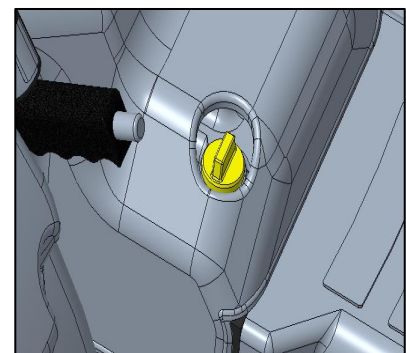

Fig.5.4

- If needed fill up through the position to the required level with oil of prescribed type.
- When operating extreme hydraulics, such as hydraulic front loaders, rams' motors etc. that require a certain amount of oil top up the additional oil of about 3-5 liters oil.
- This ensures a correct oil level in the transmission at any time.
- The level must never be under the Min. mark when using external hydraulics.
- The level must always be between the Min and Max marks.
- When working with the tractor with the slopes, add extra liters of oil to guarantee a minimum oil level even in the most difficult conditions.
- The hydraulic ram of the implements being hitched to the tractor contains the same oil used in the transmission of the tractor.
- This excludes any oil contamination that could cause malfunction.

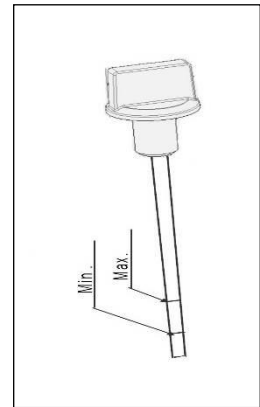

Fig.5.5



If leak is found and any other defect that cause the oil level to drop, immediate action is required to avoid any damage to mechanical systems.



Check at regular intervals the oil level in the gearbox, the rear final drives and in the hydraulic lift and steering circuits.



Park the tractor on the flat ground, stop the engine and lower the hydraulic lift links.

See the lubricants and fuel chart for the type of oil to be used according to the transmission type.

5.20 RECOMMENDED GEAR OIL VISCOSITY ACCORDING TO AIR TEMPERATURE

- We recommend use of SAE-5W30 UTTO oil grade for transmission and oil brakes.
- Refer the chart for appropriate oil viscosity according to the ambient temperature.

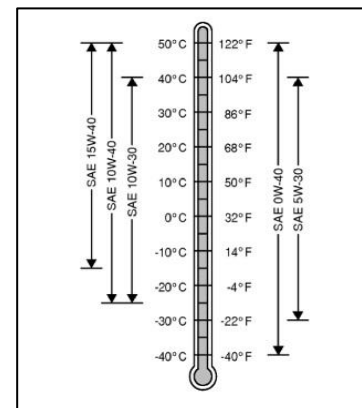

Fig.5.6

5.21 FRONT DIFFERENTIAL OIL LEVEL

- Oil filling plug (A) is provided on right hand side of the front axle (as shown in fig.).
- Open the plug and check the oil level.
- The lower point of the plug should be immersed in the oil.
- Front Differential Oil Capacity: 2.5 Liters
- Oil Grade: SAE-5W30 UTTO

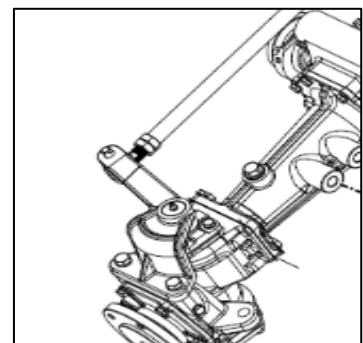

Fig.5.7

5.22 RADIATOR COOLANT LEVEL (HOT)

- NEVER remove the plug from the radiator while the engine is still hot.
- Slowly open the radiator cap up to the safety catch (about 1/3 turn).
- Wait to allow the steam to escape.
- Continue opening the cap, press it down firmly to release the safety catch.
- The level of coolant should just touch the tab located in the filling spout.
- If the level has dropped, check the entire cooling system for leakage (radiator, hoses etc.)
- If there is no leakage, Top up the coolant. Fill the reserve tank with coolant up to the FULL line mark for coolant Top up.
- Coolant is mixture of water and anti-scaling / anti-rusting agent in recommended ratio.

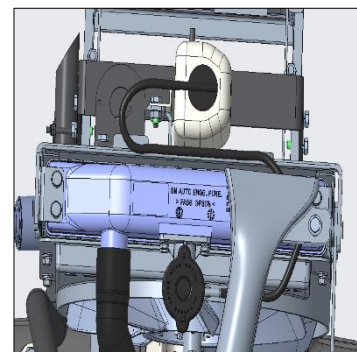

Fig.5.8

5.23 PRECAUTIONS AGAINST FREEZING TEMPERATURES:

- To prevent ice from forming in the radiator, add specific products according to the instructions given by the antifreeze manufacturer.
- Antifreeze also possesses antioxidant and rust inhibiting properties and is suitable for all seasons.
- In Sub Zero Temperature climate conditions use Ethylene Glycol Antifreeze Agent along with water in following ratio.

Temperature Range °C	0 To -3	-3 To -8	-8 To -16	-16 To -25	-25 To -37	-37 To -55
Antifreeze (%)	10	20	30	40	50	60

- This mixture can be permanently maintained in the circuit for 1 year so long as you have not totalized 1000 hours service during this period. In this case, the mixture must be changed.
- Flush out the system whenever you change from using pure water to antifreeze mixture and vice versa.

5.24 REPLACEMENT OF ENGINE OIL FILTER

1. Remove the oil filter by rotating it in anti-clockwise direction by hand or with the filter wrench.
2. Take new oil filter and check it for proper seating of gasket.
3. Apply clean engine oil to gasket on the new oil filter.
4. Install oil filter.
5. When the filter gasket contacts the mounting surface of filter, tighten the new oil filter.



Fig.5.9

5.25 CHANGE AND REFILLING OF ENGINE OIL

1. Stop your tractor to the side of road on leveled surface and drain the engine oil in an oil pan after removing the drain plug.
2. Re-install the Drain plug and remove the oil filler cap.
3. Fill the engine oil with the specified engine oil SAE15W40) to the specified level to sump capacity (4.2 Ltr.) from oil filler cap.
4. Insert into the oil level gauge guide, then pull out the gauge again.
5. Ensure that oil level should be between the MAX. & MIN. marks on the oil level gauge.
6. If less, then pour the oil to bring it to specified level.
7. Install the oil filler cap after a refill.
8. Check the oil pan and other parts for oil leakage.
9. Start the engine, allow it to run idle and don't race it immediately.
Only use genuine filter cartridges. Use of non-genuine cartridges could damage the engine and shorten its working life.

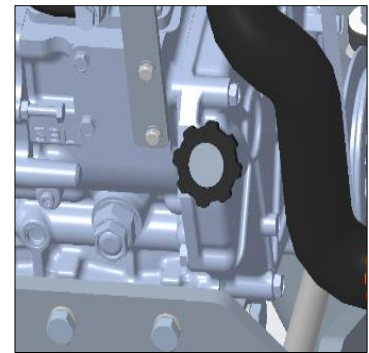

Fig.5.10



5.26 REPLACEMENT OF ENGINE FUEL FILTER

1. Shut down fuel cock.
2. Remove the filter by rotating it in anti-clockwise direction by hand or special wrench.
3. Take new filter and check it for proper seating of gasket.
4. Apply clean engine oil to gasket on the new fuel filter.
5. Install fuel filter, when the filter gasket contacts the mounting surface of filter, tighten the filter and ensure that there is no leakage.

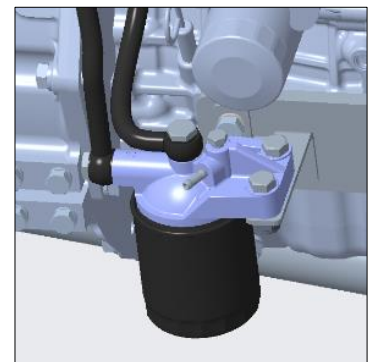

Fig.5.11

5.27 AIR BLEEDING OF FUEL SYSTEM

After changing the fuel filter, the system must be air – bled in following manner:

1. Switch ON the ignition key to start the electric pump till completion of air bleeding process.
2. Loosen the vent plug (A) at the top of fuel filter body.
3. Tighten the vent plug (A) until the bubble free fuel flows from the air vent plug hole.
4. Loosen the return valve (B) of FIP and allow the air to flow out from the system.
5. Tighten the vent plug (B) until the bubble free fuel flows from the return valve.
6. Loosen the injector pipes (C) and crank the engine till the bubble free fuel flow is ensured.
7. Tighten all the injectors.

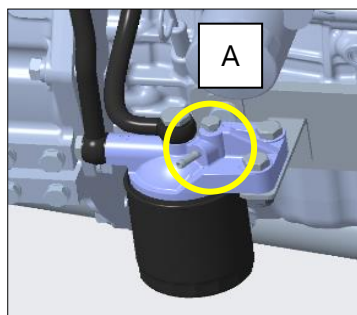

Fig.5.12

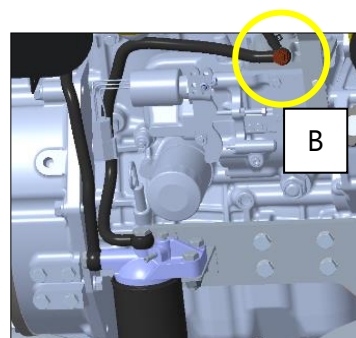

Fig.5.13

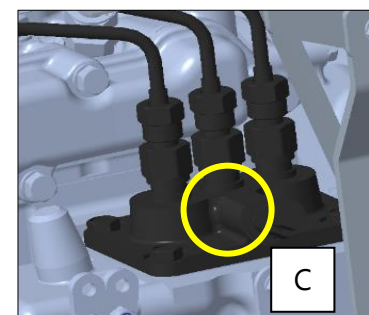

Fig.5.14

5.28 REPLACEMENT OF TRANSMISSION, REAR FINAL DRIVES AND POWER LIFT HYDRAULIC CIRCUITS OIL

1. Lower the lift arms to the ground.
2. Remove the plugs located at LH side of lower portion of brake housing to make oil draining easier.
3. Place vessel under all drain plugs of transmission housing to collect the oil as it drains out.
4. Remove the plugs and drain out the oil. Clean the plugs and fit back on.

NOTE: When draining out and filling oil and checking oil level, take care that the transmission is in horizontal position.

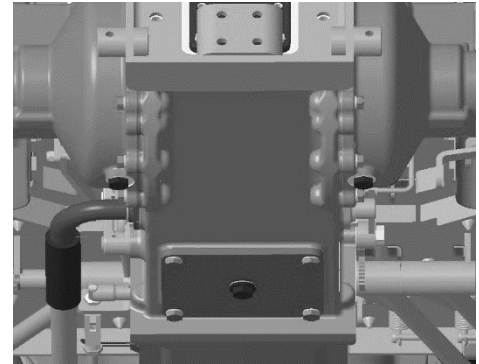

Fig.5.15

FILLING UP THE TRANSMISSION

1. Fill up the transmission to the maximum level mark on the dipstick.
2. Put the gearshift lever in neutral and start the Engine.
3. Let it run on idle until the oil reaches a temperature over 25°C.
4. Check that the transmission oil reaches the required level mark on the dipstick.
5. If required, fill up to the correct level.

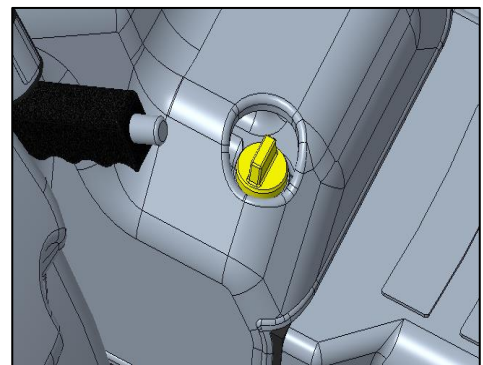

Fig.5.16



See the Lubricants and Fuel chart ' for the type of oil to be used according to the transmission type.

NOTE: If implements are used that require a great quantity of oil, make sure that the transmission contains enough oil for every work condition. Top up as required. Let the oil stabilize before checking its level.

5.29 RADIATOR DRAINING & FLUSHING (WHEN COLD)

1. Remove the radiator cap and drain plug (A).
2. Let the coolant drain out. Close drain cock and plugs.
3. Flush the cooling system with water / Cleaning Solution for 15 minutes, then drain the cleaning solution.
4. Refit the drain plug and refill the coolant (Mixture of water, anti-scaling agent, antifreeze).
5. Run the engine with radiator cap open and accelerate 2-3 times and Top up coolant if required.
6. Refit the radiator cap and ensure tightness all the connections for any leakage.

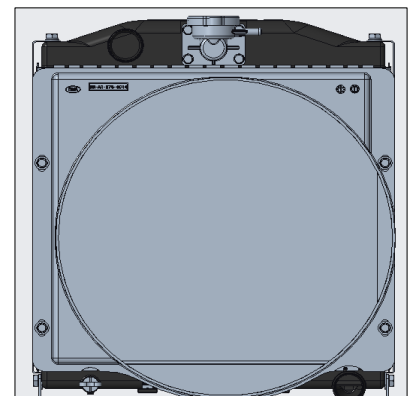

Fig.5.17



NEVER remove the radiator cap when the engine is hot.

5.30 RADIATOR FINS CLEANING

1. Periodically check to make sure that the radiator (D (Fig. 5-7) is not clogged.
2. Clean with a jet of compressed air directed from the inside towards the outside.



These operations must be carried out when the engine is cold. When hot, the grilles and radiator will burn the hands and fingers.

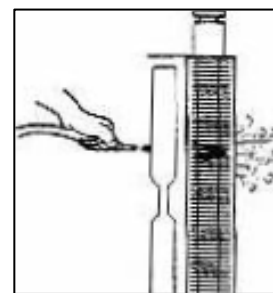

Fig.5.18

NOTE: The best results are obtained with a steam cleaver that softens up the dirt. Use a lamp to check the cleaning between the radiator fins. We recommend a daily cleaning when Tractor is used in the excess dust operation and chances of radiator chocking.

5.31 RADIATOR CAP

- Cooling system is closed pressurized system so don't operate the tractor without radiator cap or cap with damaged rubber seals/defective release valve to avoid water loss and engine overheating.
- Use genuine radiator cap only.



Fig.5.19

5.32 CHECK OR REPLACE HOSE PIPES

- Check hoses regularly – on every service/before cranking tractor after long idle standing– for leaks, kinks, cuts, tears, rubbing, bulges, corrosion, exposed fabric and other signs of wear and damage.
- Replace worn or damaged hoses immediately.
- Replacement hoses are available from your dealer.

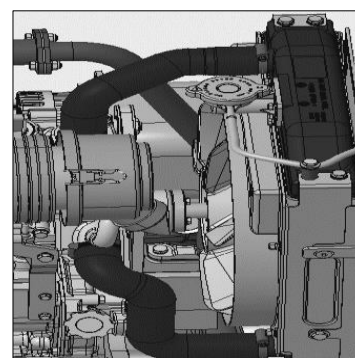

Fig.5.20

5.33 DRY TYPE AIR FILTER

Dry Air Filter Consists Of:

- Air Filter Housing/Element
- Clamp
- Cover
- Rubber Valve
- Air Cleaner Element – Primary & Secondary Element

Discharge the dust deposits and sediments each day by pressing the rubber valve (Fig. 5.21) on the air filter housing.



Fig.5.21

5.34 IMPORTANT INSTRUCTIONS FOR AIR FILTER



Always stop the engine before ' demounting the filter elements.

- Periodically release the clips, remove the cover, take out the external cartridge and clean it (this operation should be carried out more frequently if you work in a very dusty environment).
- Clean the primary element at first 50 hrs. & then after every 250 hrs. of operation or immediately when the red band appears on the service indicator.
- Never remove the secondary element for cleaning. Only remove when replacement of it is required.
- Replace primary & secondary element upon 3rd cleaning requirement of the primary element or at 750 hrs. (whichever occurs earlier)
- Gently pull filter element backwards to remove filter out from housing.
- Use clean cloth to wipe sealing areas of filter element without removing secondary element.
- Ensure proper seating of filter into housing before latching the cover. Do not use latches on the cover to force the filter into air cleaner which could cause damage to housing & will void warranty.
- the vacuator valve should always be in perfectly downward direction



Fig.5.22



**CLEAN PRIMARY ELEMENT ONLY BY TAPPING VERTICALLY ONLY ON CLEAN FLOOR. DON'T TAP DIAGONALLY/ AT AN INCLINED ANGLE.
SECONDARY ELEMENT SHOULD NOT BE CLEANED OR REMOVED DURING CLEANING OF PRIMARY ELEMENT.**

**NEVER ATTEMPT TO CLEAN THE FILTER ELEMENT WITH EXHAUST GAS FROM THE ENGINE.
NEVER EVER USE OIL ON DRY FILTER.
NEVER EVER USE OIL, DIESEL FUEL, PARAFFIN OR SOLVENTS TO CLEAN THE FILTER ELEMENT.**

5.35 CLEANING OF SUCTION STRAINER

- At each oil change, thoroughly clean suction strainer by washing with light oil or kerosene.
- Failure to observe this will result in extensive shortening life of hydraulic system.

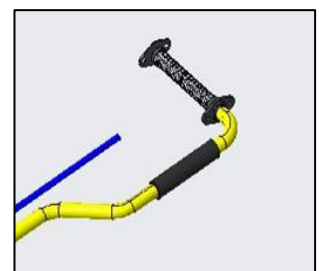

Fig.5.23

5.36 STEERING CYLINDER KNUCKLE

- The steering cylinder knuckle joint nuts (1) checked by an authorized service center at every service.

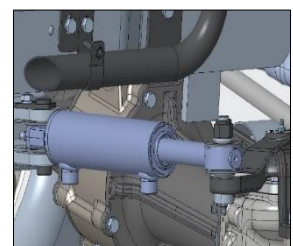

Fig.5.24

5.37 CLUTCH PEDAL

- Check the free travel of the gearshift clutch pedal at suitable intervals.
- Excessive play reduces the disengaging travel of the clutch and could prevent the gears from being correctly meshed.
- On the other hand, insufficiently play could lead to abnormal wear on disengaging thrust bearing, overheating and rapid wear on the clutch itself.
- Do not keep foot on clutch pedal while tractor is in running condition. It may cause excessive wear of clutch and clutch fails before its lifetime.

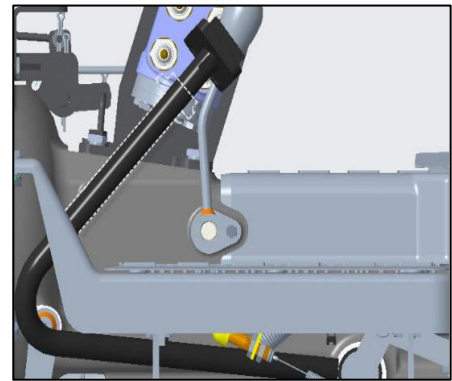

Fig.5.25

5.38 METHOD TO CHECK CLUTCH PEDAL FREE PLAY

- Press down the clutch pedal and measure the free play of pedal as shown in the figure (Fig. 5-11).
- The distance should be 25 to 30 mm.
- If the distance is less than 25 mm or higher than 30 mm then get it adjusted

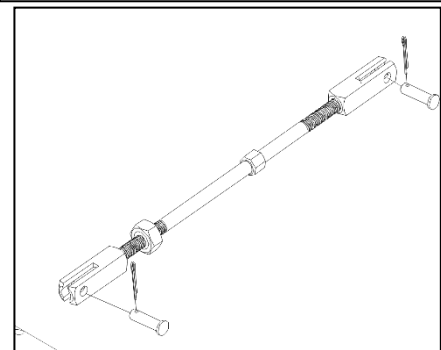

Fig.5.26

5.39 METHOD TO ADJUST CLUTCH PEDAL FREE PLAY

- Loosen the Fork and check nut (1)
- To restore the pedal travel 'A'
- Then fit the Fork back again and lock the Check nut.

5.40 BRAKE PEDAL

- Use independent brake in the field operations.
- In field you will turn more sharply by pressing brake pedal for the side wheel on the turn.
- The pedals must be locked for road use.

5.41 METHOD TO CHECK BRAKE PEDAL FREE PLAY

- Release the hand brake. Uncouple the two pedals.
- Press down the right-hand pedal and measure the free play of pedal as shown in the figure.
- The distance should be between 35-40 mm.
- If the free play is less than 35 mm or higher than 40 mm then adjust the both hex nut on actuator tie rod until free play comes to 35 to 40 mm.
- Now, press down the left-hand pedal, If the values are not equal with the right-hand pedal, then repeat the same procedure until values come equal.

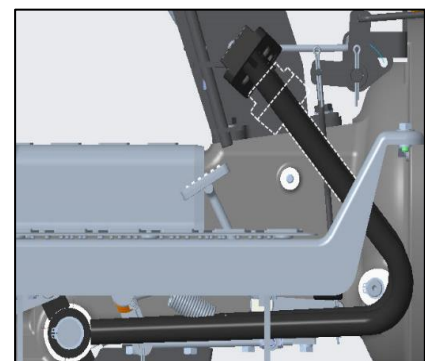

Fig.5.27

5.42 METHOD TO ADJUST BRAKE PEDAL FREE PLAY

- Adjusting the brakes for the first time after the first 50 hours, then according to the work conditions.
- The braking system must be adjusted when the free travel of the pedals (Fig. 5-12) becomes excessive and the pedals are near to end of travel.
- Proceed in the following way to restore free pedal travel to its normal value of about 15-20mm (Dimension A):

1. Jack up the rear wheels of the tractor.
2. Make sure that the parking brake is off.
3. Free the brake pedals by raising the lock.
4. Unscrew the check nut (1) (Fig.5-13). Slowly, tighten the adjuster (1) (Fig.5-13) until you can no longer turn the wheel by hand.
5. Make a reference mark on the adjuster nut (Fig.5-13) and on the support, then slacken off the adjuster nut by 1 turn, i.e. until the wheel can be freely turned.
6. Now lock the adjuster with the relative check nut (1) (Fig. 5-13). Check that the brake pedal has a free travel of 15-20mm and repeat the adjustment if necessary.
7. Repeat the same procedure for the other side (Fig. 5-13).
8. Finally, check that the free travel is the same for both pedals and that the brakes engages simultaneously on both sides.



Difference in the free play will lead to unbalanced brakes, the tractor can slew in the event of violent braking. The wheel on which the brakes are applied locks and the tyre wears out quickly. During Road Operations both the brake Pedals should be locked.

5.43 PARKING BRAKE

- The parking brake lever acts directly on the main brakes.
- Make sure that free travel is identical for both pedals, since free travel of the pedals dictates the free travel of the parking brake and left/right distribution of the braking action when the brakes are locked.
- Once you have adjusted the brake pedals, adjust the free travel of the parking brake. (Fig.5-14) on the control linkage on the left side of the tractor, so that the parking brakes engage after clicks of the ratchet mechanism, sensed on the release button (2) of the lever (1).

5.44 BATTERY

- Your tractor is equipped with a "Maintenance Free battery." Keep the battery clean and dry, particularly on top.
- Specifications: 12V, 65 Ah

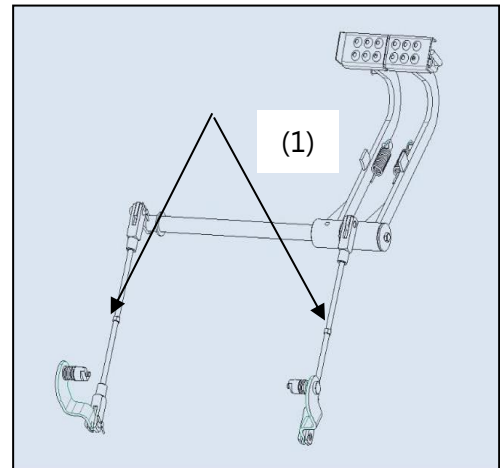

Fig.5.28

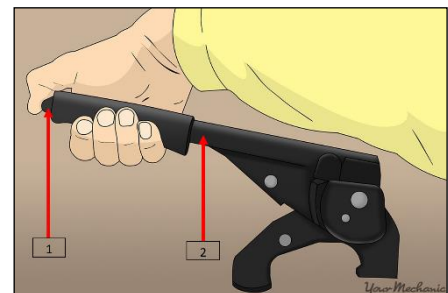

Fig.5.29

5.45 BATTERY REMOVAL PROCEDURE

Battery is located at front of the tractor as shown in the figure, follow the below procedure to access the battery:

1. Open the bonnet.
2. Remove the fly nut (1) by rotating it anticlockwise.
3. Detach the (-)ve terminal first and then (+)ve terminal (2).

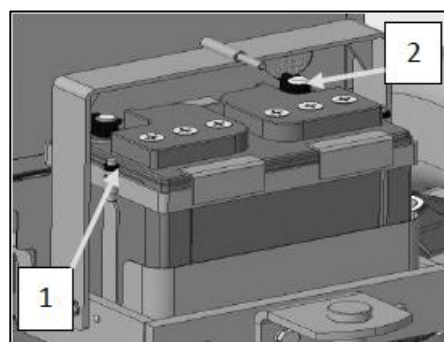

Fig.5.30

5.46 CHECK ELECTROLYTE LEVEL

- It should just touch the upper mark and never be under the bottom mark.
- It is advisable to periodically check the level of battery acid and to add distilled water if necessary.
- Recharge the battery thereafter.
- NEVER top up with SULPHURIC ACID
- If you need to top up more frequently, have the battery charging system checked by a qualified technician.

NOTE: The level of the electrolyte must be checked with the engine off, the tractor parked on the flat ground and the battery cold.

NOTE: Make sure that the battery terminal nuts are well fixed to their terminals.

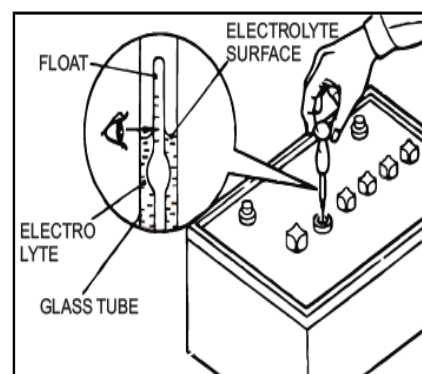

Fig.5.31

5.47 BATTERY CHARGING PROCEDURE

- Check the battery charge with a digital voltmeter as Described below:
- Connect to the two battery poles, matching their terminals with the same sign (negative with negative and positive with positive).
- Now read the measured value on the instrument and compare this value with the ones in the table to establish the battery charge status.
- When the voltage is near 12.30V, the battery must be immediately charged with current equal to 1/10 of the capacity in Ah (a 65 Ah battery must be given a 5 Amp charge).

Voltage (V)	Charge Status
12.66 V	100 %
12.45 V	75 %
12.30 V	50 %
12.00 V	25 %

- Protect against freezing.
- Ensure that terminals are clean and tight.
- Check specific gravity of battery using a battery hydrometer.
- Specific gravity of a fully charged battery is 1.265 ± 0.005 at 27 °C.
- Do not use quick battery chargers to recharge the Batteries.

5.48 BATTERY REPLACEMENT PROCEDURE

Proceed as described below when the old Battery must be replaced with a new one:

1. First disconnect the terminal with the negative (-) sign and then the one with the positive (+) sign.
2. Fit the new battery into its housing without tightening the fixing screws too much.
3. Clean the terminals and connect them to the battery poles. Make sure you connect the negative (-) pole last.
4. Fully tighten the terminal screws on to the poles and protect them with Vaseline.
5. Never short circuit or earth any of the alternator terminals.
6. This could damage the electrical system
7. Never invert the alternator connections.
8. The battery and alternator earths must be of the same sign or the alternator diodes will be damaged.
9. Always disconnect both the alternator terminals before undertaking any electrical arc welding on the tractor.

5.49 HAZARD RELATED TO BATTERY

- Battery electrolyte contains sulphuric acid and can cause serious burns.
- Battery gas can explode. Keep sparks and flames away from batteries.
- Use a flashlight to check battery electrolyte.
- Keep naked flames, sparks and lighted cigarettes away from batteries which are being charged.
- When connecting the battery to a charger, make sure that positive (+) lead of the charger is connected to the positive of the battery and the negative (-) to the negative.
- Incorrect connection will damage the diodes and the other circuit components.
- Battery pots, terminals and related accessories contain lead and lead compounds, chemicals known to the State of California to cause cancer and reproductive harm.
- Wash hands after handling.
- Remember to disconnect the cables before you recharge the battery.
- It is advisable to remove the battery from its housing and to recharge it well away from the tractor.
- Do not smoke or work with tools liable to produce sparks whilst the battery is being recharged. Never Patch up the electrical circuits.
- Never replace a blown fuse by a higher capacity fuse, it could cause a fire.
- Never work on components such as the alternator or starter motor when the engine is running.
- Lastly when you are cleaning the tractor and using the pressure spray, take care not to damage the connections on the various electrical cable.

5.50 AVOID BATTERY HAZARD BY:

- Filling batteries in a well-ventilated area.
- Wearing eye protection and rubber gloves.
- Avoiding use of air pressure to clean batteries.
- Avoiding breathing fumes when electrolyte is added.
- Avoiding spilling or dropping electrolyte.
- Using correct battery booster/charger procedure.

5.51 IF ACID IS SPILLED ON SKIN OR IN EYES

- Flush with water.
- Apply baking soda/lime to help neutralize the acid.
- Flush eyes with water for 15-30 minutes. Get medical attention immediately.

5.52 IF ACID IS SWALLOWED

- Do not induce vomiting.
- Drink large amounts of water or milk, but do not exceed 2 L (2 qt.)
- Get medical attention immediately.

5.53 ALTERNATOR (12V, 65A)

- Alternator is fitted on Left side of engine and generates current which charges battery for electrical back up.
- Visually check the alternator for damage.
- If the alternator is dusty, blow off dust using compressed air.
- Remove V-belt and turn the pulley with hands to make sure it rotates smoothly.
- If defects are found in the alternator, contact your dealer.

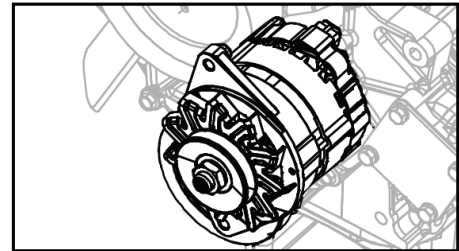

Fig.5.32

5.54 STARTER MOTOR (12V, 1.6kW)

- Starter motor is mounted on the left side of the engine.
- The starting motor rotates the engine crankshaft for starting.
- Visually check the starter for damage.
- If starter is dusty, blow off dust using compressed air.
- If defects are found in the starter, contact your dealer.

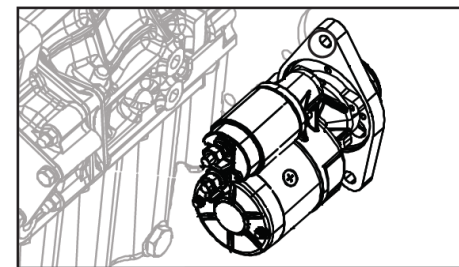

Fig.5.33

5.55 CHECKING V-BELT

- Ensure that V-Belt is free from defects such as wear, cuts or surface separations, otherwise replace with genuine specified belt.
- Inspect belt tension by pushing the belt downward with approx. 98N (10kgf) (22lbf) force midway between pulleys.
- If the deflection is 10 to 12mm, the tension is correct.
- If the tension out of the specified value, adjust belt tension.

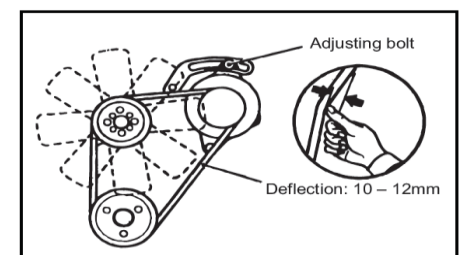

Fig.5.34

5.56 ADJUSTING V-BELT TENSION:

- Loose all retaining bolts of the alternator and adjusting plate.
- Insert a bar between the alternator and cylinder block and use leverage to move that alternator to have proper v-belt tension. While V-belt tension is appropriate, retighten all the retaining bolts of the alternator and adjusting plate.

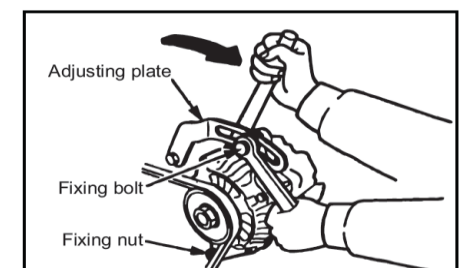

Fig.5.35

5.57 MISCELLANEOUS INSPECTIONS

- Hand brake lever: make sure that the ratchet mechanism locks in a secure and stable way.
- Make sure that the wheel nuts are correctly torque. Make sure that the safety frame screws are well tightened.
- Make sure that all other nuts and bolts are well tightened.
- Check the tires pressure.

5.58 DASHBOARD CONTROL COATINGS

- Use water and a neutral detergent to clean the coating of dashboard and controls.
- Any commercial product to clean car interiors may be used.
- DO NOT use any kind of solvents or alcohols.

5.59 FUSES

Fuses against short circuits and excessive power draw protect the tractor's electrical system. The number of the fuses in the electrical system depends on the tractor model. Before replacing a blown fuse with a new, equivalent ohm, the cause that lead to the fault should be ascertained and removed.

The fuses are contained in suitable box:

FUSE IN FUSE BOX		
SR. NO.	CATEGORY	FUSE (A)
1	Head Light Low Beam	20 A
2	Head Light High Beam	20 A
3	Parking Light	15 A
4	Indicator Left Side	15 A
5	Indicator Right Side	15 A
6	Fuel Feed Pump	15 A
7	ECU	20 A
8	Plough Light, Cluster, Brake Light	15 A

There is an additional fuse of 60A placed near the glow tech unit, in front of radiator

5.60 SEVEN PIN SOCKET FOR TRAILER

Seven Pin socket is installed on the rear side of tractor.

This socket is used to connect the light circuit of the trailer.



Fig.5.36

5.61 CONNECTION FOR SEVEN PIN SOCKET

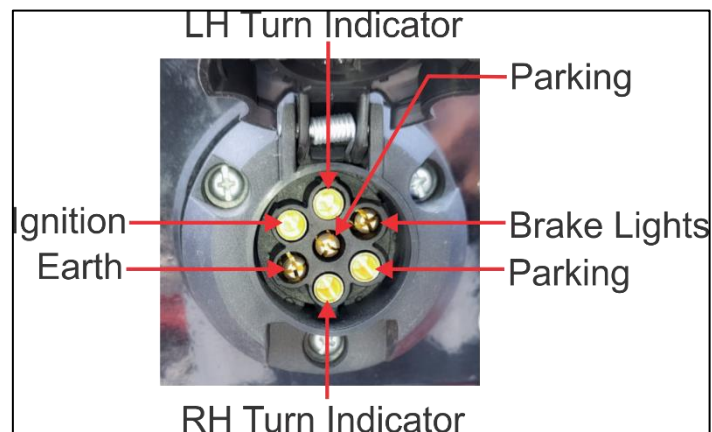

Fig.5.37

5.62 LONG IDLE PERIOD

Take the following precautionary measures when your Tractor is not going to be used for a long period of time.

- Park the tractor in dry sheltered place.
- Drain the coolant from the radiator and engine.
- Grease all points provided with grease nipples.
- Empty the fuel from the tank and filter bowl and clean the fuel filter.
- Generally, clean the tractor particularly the bodywork components.
- Protect the painted parts by applying silicon wax and the unpainted metal parts by applying protective lubricant.
- Park the tractor in a dry, sheltered and possibly ventilated place.
- Make sure that all the controls are in neutral (including the electric switches and parking brake controls).
- Remove the ignition key from ignition switch & off battery isolator switch.
- Empty the fuel tank and fill with it with new diesel fuel until the maximum level is reached.
- Remove the battery, clean the cover and spread Vaseline on the terminal and terminal caps.
- Now connect the battery in the ventilated place where the temperature is not liable to drop below 10 and where it is not exposed to direct sunlight.
- Check the battery charge with a voltmeter as described in the battery part of this section Recharge if it is necessary.
- Place stands or other supports under the axles in order to take the weight off the wheels.
- When the tractor is raised in this way, it is advisable to deflate the tires.
- If this is not possible, the tire pressure must be periodically checked.
- Cover the tractor with a tarpaulin (not plastic or waterproof).
- At the end of the idle period, when you start the engine again, pay attention to the instruction about starting engine in the operation chapter.

5.63 GREASING POINTS AVAILABLE ON THE TRACTOR

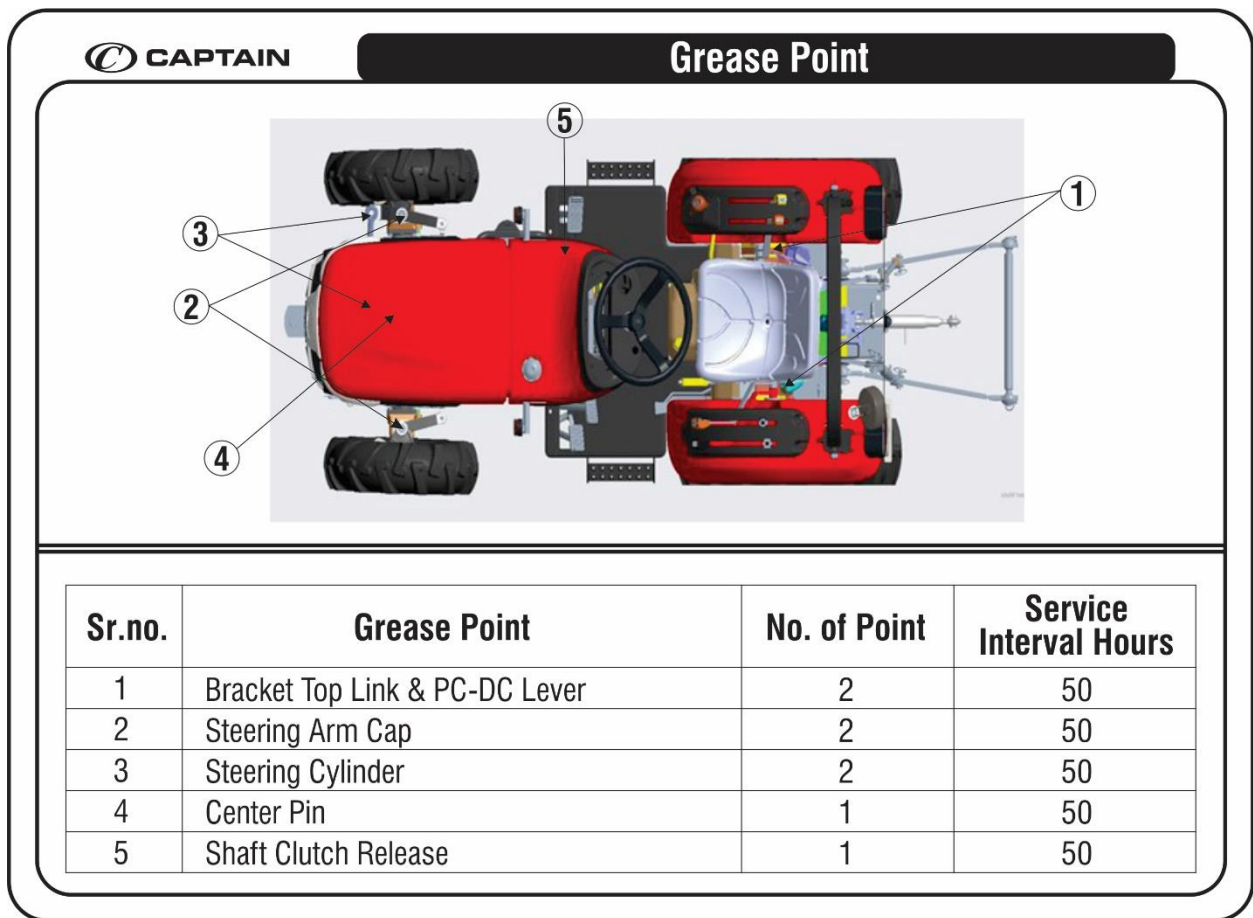
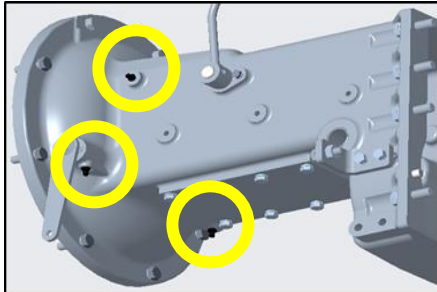

Fig.5.38

5.64 GREASING POINTS

1. Clutch Housing: 3 Points



2. Front Axle Center Pin: 1 Point

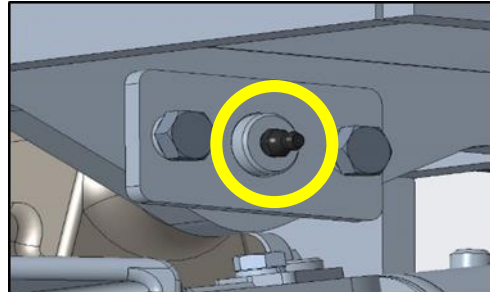

3. Front Differential: 2 Points

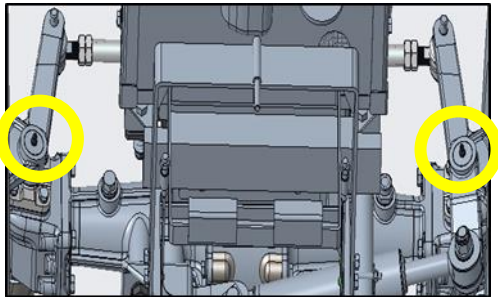

4. Power Steering Cylinder: 1 Point

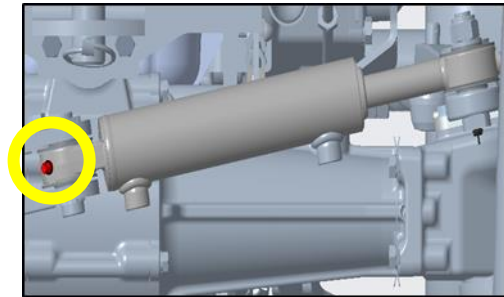

5. Power Steering Cylinder Knuckle Joint (On steering arm double side)

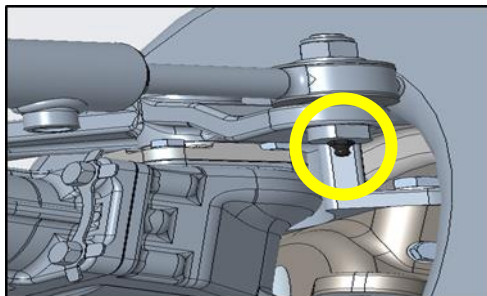

6. Hydraulic Assembly: 2 Points

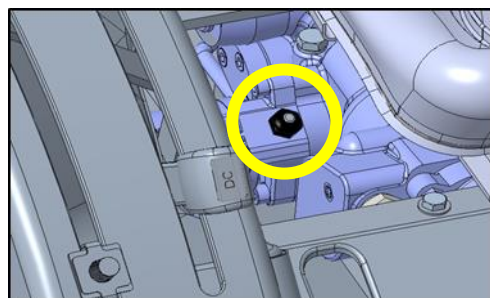
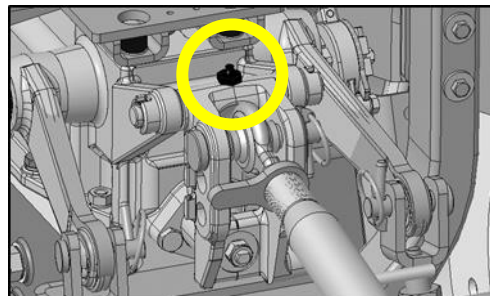

5.65 WIRING CIRCUIT DIAGRAM

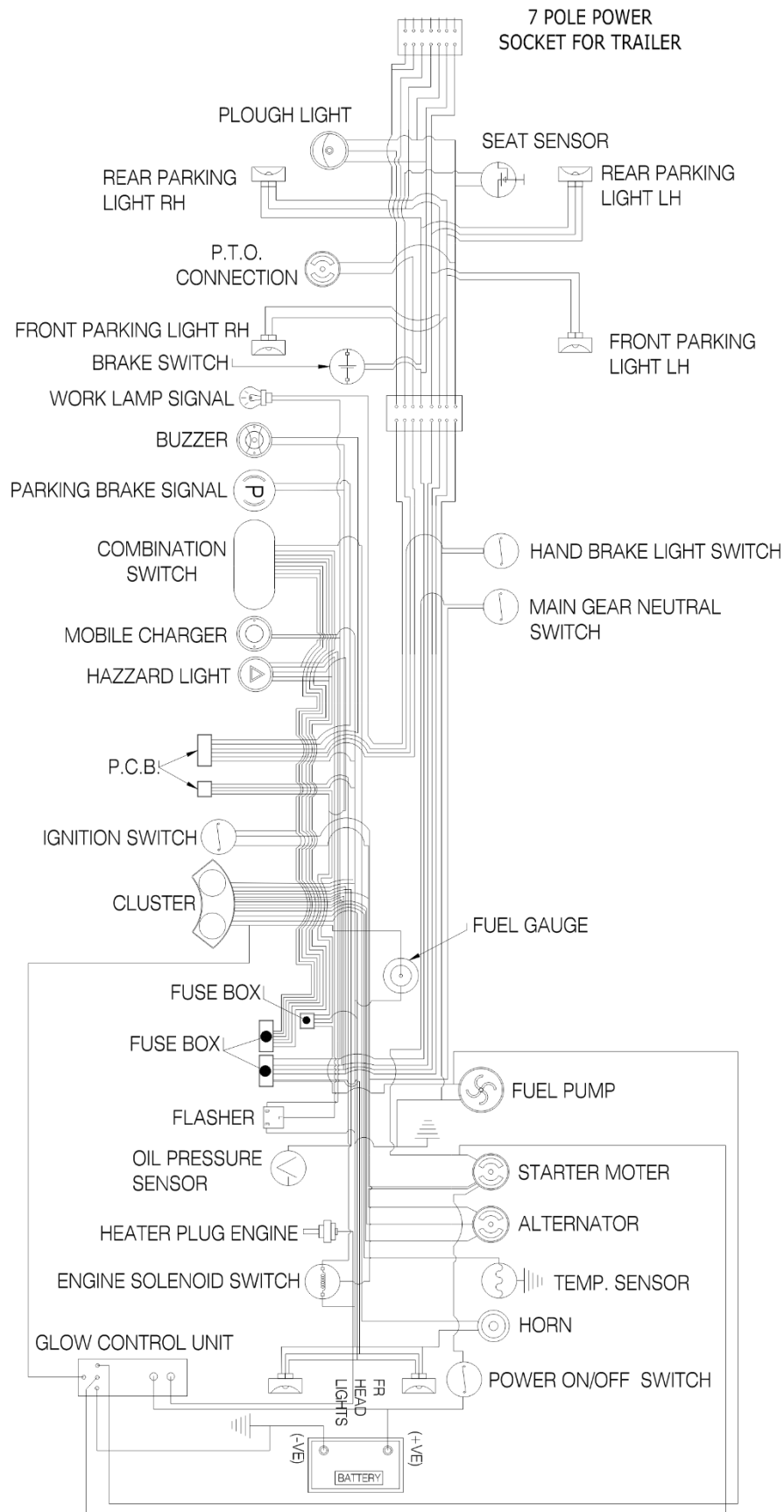

CHAPTER -6 TECHNICAL SPECIFICATION

ENGINE	Engine Type	4 Stroke Diesel Engine
	Engine H.P.	25 H.P.
	No. Of Cylinders	3
	Aspiration	Natural
	Bore x Stroke	78 mm x 92 mm
	Displacement	1319 cc
	Rated RPM	2500
	Maximum Torque @ RPM	76.3 Nm @ 2000 RPM
	Air Cleaner	Dry Type 2 Stage
TRANSMISSION	Drive	4WD
	Clutch	Single Clutch, Mechanical
	Transmission Type	Sliding Mesh
	No. of Gears	9 Forward + 3 Reverse
PTO (See Point 4.15)	Type	Type – I
	Speed	2 Speed (540 & 1000)
STEERING	Type	Hydrostatic Power Steering
HYDRAULIC	3 Point Linkage Category	Cat – I
	Lifting Capacity	600 KG @ Lower Link
FORWARD SPEED	Minimum (Km/ Hr.)	1.43 @2500 RPM
	Maximum (Km/ Hr.)	21.45 @2500 RPM
BRAKES	Type	Oil Immersed Brake
TURNING RADIUS	Turning Radius with Brake	2.45 Meter
	Turning Radius W/O Brake	3.15 Meter

LUBRICANTS AND FUELS		
AGGREGATE	CAPACITY	RECOMMENDED GRADE
ENGINE OIL	2.7 Liters	SAE – 15 W 40
GEAR BOX AND REAR AXLE	20 Liters	UTTO SAE – 5 W 30
FRONT DIFFRENETIAL	2.5 Liters	UTTO SAE – 5 W 30
FUEL	19 Liters	High Speed Diesel

UTTO = Universal Tractor Transmission Oil

***Specifications are subject to change without prior notice. Consult your nearest dealer for exact model information and detailed Specifications.

OVERALL DIMENSION

MODEL	STARTRAC 263 – 4WD					
TYRE	AGRICU LTURE	TURF	FLOTATION	AGRICULT URE WIDE	GALAXY GARDEN PRO	WIDER F- AGRI
GENERAL DATA						
Front Tyre Size	180/85D12	23 x 8.50 – 12	23 x 8.50 – 12	6.5/80 – 12	220/55R12	23 x 8.50 – 12
Front Tyre Pressure (Kg/Cm ²)	2.53	1.54	2.46	2.53	1.79	1.00
Rear Tyre Size	8.30 x 20	33 x 15.5 – 16.5	33 x 15.5 – 16.5	280/70R – 18	280/70R – 16	280/70R – 18
Rear Tyre Pressure (Kg/Cm ²)	2.46	1.54	1.54	1.54	1.58	1.54
Length* Max. (mm)	2824	2824	2824	2824	2824	2824
Length* Min. (mm)	2674	2674	2674	2674	2674	2674
Width (mm)	1027	1479	1483	1167	1217	1167
Height (mm)	2106	2082	2078	2086	22057	2086
Weight (Kg)	950	992	1020	952	959	956
Wheelbase (mm)	1500	1500	1500	1500	1500	1500
Ground Clearance Min. (mm)	220	220	220	220	220	220
Front Track Width (mm)	920	1020	1020	920	1020	1020
Rear Track Width (mm)	813	1083	1083	885	938	885

*Length Max. is with extra long lower links while length min. is with regular lower links.

CHAPTER - 7 DO' AND DON'TS

DO'S	DON'TS
ENGINE	
A. General	A. General
<ul style="list-style-type: none"> Do release the starter key once the engine has started. 	<ul style="list-style-type: none"> Do not race the engine in neutral condition
<ul style="list-style-type: none"> Do check the proper functioning of oil pressure gauge and battery charging indicator once the engine has started. 	<ul style="list-style-type: none"> Do not keep on continuously cranking the engine with starter key. It will shorten the life of battery.
<ul style="list-style-type: none"> Do get the tightness of cylinder head and manifold nuts checked regularly 	<ul style="list-style-type: none"> Do not do unnecessary idling
<ul style="list-style-type: none"> Do switch off the engine when tractor is not in operation 	
B. Air Inlet System	B. Air Inlet System
<ul style="list-style-type: none"> Do inspect the element pre-cleaner. Clean if necessary 	<ul style="list-style-type: none"> Do not run the tractor if the air cleaner assembly is defective as this will lead to impure air being taken in and consequently excessive wear of liners and piston rings.
C. Fuel System	C. Fuel System
<ul style="list-style-type: none"> Do drain sediments from the fuel tank periodically. 	<ul style="list-style-type: none"> Do not keep the fuel tank without a proper sealing cap.
<ul style="list-style-type: none"> Do clean fuel tank thoroughly once in 500 hrs 	<ul style="list-style-type: none"> Do not use contaminated fuel as it may affect the operation of fuel injection pump and the injectors.
<ul style="list-style-type: none"> Do changes filter regularly as recommended in service schedule. 	<ul style="list-style-type: none"> Do allow leakage through fuel pipe joints.
<ul style="list-style-type: none"> Do fill diesel in the tank at the end of the day's work to avoid condensation. 	<ul style="list-style-type: none"> Do not spill fuel or oil while filling or topping up. Use a funnel.
D. Water Cooling System	D. Water Cooling System
<ul style="list-style-type: none"> Do ensure that radiator is always filled with clean (soft) water & radiator cap is tight. 	<ul style="list-style-type: none"> Do not run the tractor with the radiator cap removed/non-acting radiator cap.
<ul style="list-style-type: none"> Do clean radiator front grill to ensure free flow of air when the engine is operating. 	<ul style="list-style-type: none"> Do not remove thermostat as it will affect engine performance.
<ul style="list-style-type: none"> Do ensure proper tension of fan belt. Deflection should not be more than (10 mm) when pressure is applied between the fan pulley and the crankshaft pulley. 	<ul style="list-style-type: none"> Do not run the belt tight as it will lead to premature failure of water pump and alternator bearing.
	<ul style="list-style-type: none"> Do not run the tractor when the radiator hoses are leaking as it will lead to overheating of the engine.
	<ul style="list-style-type: none"> Do not run the belt loose as it will lead to inefficient cooling and improper charging of the battery.

E. Lubrication System	E. Lubrication System
<ul style="list-style-type: none"> Do replace engine oil after first 50hrs. of operation. Thereafter, engine oil should be replaced every 250 working hrs. 	<ul style="list-style-type: none"> Do not use wrong grade of lubrication oil.
<ul style="list-style-type: none"> Do check oil level daily with tractor parked on a level ground. 	<ul style="list-style-type: none"> Do not overfill engine oil as this can cause excessive oil consumption and oil leaks.
<ul style="list-style-type: none"> Do replace lubrication oil filter element every 250 working hrs. after first replacement at 50 hrs. 	<ul style="list-style-type: none"> Do not allow oil to leak. Ensure that the joints are adequately tight.
	<ul style="list-style-type: none"> Do not mix different brands of engine oil.

CLUTCH	
<ul style="list-style-type: none"> Do ensure that clutch free pedal play is between 250 to 30 mm. 	<ul style="list-style-type: none"> Do not coast down steep slopes with tractor in neutral/with clutch pedal pressed
<ul style="list-style-type: none"> Do ensure that the clutch pedal is release slowly while moving the tractor. 	<ul style="list-style-type: none"> Do not work the tractor by slipping and re-engaging the clutch.
	<ul style="list-style-type: none"> Do not rest the foot on the clutch pedal.

TRANSMISSION	
<ul style="list-style-type: none"> Do change the transmission oil after 750 hrs. of operation. 	<ul style="list-style-type: none"> Do not use top gears with low engine rpm
<ul style="list-style-type: none"> Do operate at optimum speed and correct gear. 	

HYDRAULIC SYSTEM & LINKAGE	
<ul style="list-style-type: none"> Do ensure that hydraulic control lever is in down position while draining the transmission oil. 	<ul style="list-style-type: none"> Do not move the operational control range to fast response, while the tractor is on a hard surface like concrete, as the implement will crash down and get damaged.
<ul style="list-style-type: none"> Do use matching trailers for transportation. Ensure proper hitching. Never overload the trailer. 	<ul style="list-style-type: none"> Do not attempt to pull or tow anything from the top link connection. It is dangerous.
<ul style="list-style-type: none"> Do adjust the top link for proper length. 	<ul style="list-style-type: none"> Do not use bolts in place of linch pins.
<ul style="list-style-type: none"> Do keep the lower links in lifted position when the tractor is moving without an implement mounted on it. 	<ul style="list-style-type: none"> Do not reverse the tractor with PTO driven implement attached and PTO lever in ground PTO position implement may get damaged in reverse.
<ul style="list-style-type: none"> Do ensure that the lift arm bolts are always tight. 	
<ul style="list-style-type: none"> Do keep the ball joints on top and lower link clean and dry. Do not lubricate them. 	
<ul style="list-style-type: none"> Do ensure that implements are raised and lowered using the control lever. 	
<ul style="list-style-type: none"> Do ensure that the hydraulic strainer is cleaned at every schedule. 	

BRAKING SYSTEM	
<ul style="list-style-type: none"> Do keep the brake pedal locked with interlocking latch when the tractor is not being used in field. 	<ul style="list-style-type: none"> Do not attempt to turn sharply using independent brakes when travelling at high speed. This may cause the tractor to overturn.
<ul style="list-style-type: none"> Do use parking brakes when the vehicle is stationary. 	<ul style="list-style-type: none"> Do not rest foot on the brake pedal.
<ul style="list-style-type: none"> Do check loose connections in linkage mechanism. 	
<ul style="list-style-type: none"> Do grease brake pedal bush, brake bracket connections. 	

FRONT DIFFERENTIAL AND STEERING SYSTEM	
<ul style="list-style-type: none"> Do lubricate the bushes and steering drag links periodically. 	<ul style="list-style-type: none"> Do not use wrong grade of oil for lubrication of steering gear box.
<ul style="list-style-type: none"> Do get the toe-in adjusted by an authorized service center periodically. It should be maintained between (3-6 mm). 	
<ul style="list-style-type: none"> Do check the tightness of front and rear wheels to recommended torque (Front wheel is 72 Nm, Rear wheel 130 Nm). 	
<ul style="list-style-type: none"> Do flush oil once a year or 1000 hrs. whichever is earlier. 	

TYRES	
<ul style="list-style-type: none"> Do operate the tractor with correct tyre pressure. This will lead to better traction, longer tyre life and better fuel consumption. 	<ul style="list-style-type: none"> Do not operate the tractor with excessive tyre pressure. Do not allow the rear wheel to slip. Use ballast, if necessary.
<ul style="list-style-type: none"> Do maintain the recommended tyre pressure for fuel efficient operation and long life of tyre. 	<ul style="list-style-type: none"> Do not allow oil, grease and some crop spray containing considerable amounts of acid and alkalis to contaminate the tyre. These can cause considerable damage to the tyre if they penetrate into plies through small holes or splits.
	<ul style="list-style-type: none"> Do not use worn out tyre.

ELECTRICALS	
<ul style="list-style-type: none"> Do ensure that the battery terminals are kept clean. 	<ul style="list-style-type: none"> Do not change leads of the battery terminals as this will lead to failure of electric components.
<ul style="list-style-type: none"> Do ensure terminal base is lubricated with petroleum jelly. 	<ul style="list-style-type: none"> Do not do any welding in the tractor without disconnecting battery terminals.
<ul style="list-style-type: none"> Do clean the switches periodically using a jet of air. 	<ul style="list-style-type: none"> Do not leave the battery leads in the connected position if the tractor is not going to be used for a long period of time.
<ul style="list-style-type: none"> Do earth the tractor by wrapping a chain 	<ul style="list-style-type: none"> Do not overfill the battery with distilled water.

around the front axle, dropping one end of the chain on the ground while working with stationary PTO driven implement. This saves the electric equipment from damage due to static electricity.	The level should be just enough to submerge the battery plates.
-------------------------------------------------------------------------------------------------------------------------------------------------------------------------------------------------	-----------------------------------------------------------------

FOR BETTER PERFORMANCE & SAFE OPERATION	
<ul style="list-style-type: none"> • Ensure that safety shields are in place and in good condition. 	<ul style="list-style-type: none"> • Do not run the engine with the air cleaner disconnected.
<ul style="list-style-type: none"> • Read all operating instructions before commencing to operate tractor. 	<ul style="list-style-type: none"> • Do not start the tractor in an enclosed building unless the doors and windows are open for proper ventilation.
<ul style="list-style-type: none"> • Keep the air cleaner clean. 	<ul style="list-style-type: none"> • Do not operate the tractor or engine while lubricating or cleaning.
<ul style="list-style-type: none"> • Fit new sealing rings when the filter elements are changed. 	<ul style="list-style-type: none"> • Do not temper with the fuel injection pump, (If the seal is broken) the warranty becomes void.
<ul style="list-style-type: none"> • Watch the oil pressure gauge or warning light and investigate any abnormality immediately. 	<ul style="list-style-type: none"> • Do not allow the engine to idle for a long period.
<ul style="list-style-type: none"> • Ensure that the transmission is in neutral before starting the engine. 	<ul style="list-style-type: none"> • Do not use the independent brakes for making turns on the highway or at high speeds
<ul style="list-style-type: none"> • Keep all fuel in cleans storage and uses a filter when filling the tank 	<ul style="list-style-type: none"> • Do not refuel the tractor with the engine running.
<ul style="list-style-type: none"> • Attend to minor adjustments and repair as soon as the necessity is apparent. 	<ul style="list-style-type: none"> • Do not start the engine with the PTO engaged.
<ul style="list-style-type: none"> • Allow the engine to cool before removing the radiator filler cap and adding water, remove the radiator cap slowly. 	
<ul style="list-style-type: none"> • Shift into low gear when driving down steep hills. 	
<ul style="list-style-type: none"> • Latch the brake pedals together when driving on a highway. 	

CHAPTER - 8 TROUBLESHOOTING

PROBLEM	POSSIBLE CAUSE	REMEDY
ENGINE		
Engine Not Starting	Wrong way of starting engine	Use proper way of starting
	No fuel	Check fuel level
	Air trapped in fuel system	Bleed the fuel system
	Checking of fuel system	Contact your dealer
	Fuel injector faulty	Replace
	Fuel filter choke	Replace filters
Engine Not Running in Proper Way	Fuel filter choke	Replace filters
	Low quality of oil	Drain diesel from tank and fill clean diesel
	Chocking of fuel system	Check fuel system
	Fuel injector faulty	Replace fuel injector
More Oil Consumption	Oil level is more than maximum level	Keep oil level up to mark
	Oil quality is not good	Use genuine oil
Engine Not Giving Max. Power	Leakage of oil	Check and repair
	Heavy load on engine	Decrease load or shift in low gear
	Air cleaner dirty	Clean air cleaner
	Fuel filter chock	Replace filter
	Engine overheating	Check cooling system
	Engine operating temperature is less	Check thermostat
	Valve clearance not proper	Adjust through authorized dealer
	Throttle system not working properly	Check & repair through authorized dealer
Engine Abnormal Noise	Oil level less	Top up
	Oil pressure less	Check through authorized dealer
	Engine is overheated	Check and find reason
	Improper tapped setting	Adjust through authorized dealer
Oil Pressure Indicator Shows Warning	Oil level less	Top up oil up to level
	Oil quality is not good	Use genuine engine oil
	Oil pump not working	Check & repair through authorized dealer

Engine Overheating	Radiator cap faulty	Replace with new one
	Choked radiator fins	Clean it
	Oil level is less	Top up to level
	Coolant level is less	Check level and leakage of system and top up
	Slippage of fan belt	Check belt tension
	Thermostat faulty	Replace
	Chocking of cooling system	Clean the cooling system
	Water temp. gauge not working	Check through dealer and faulty replace
	Engine gets overload	Decrease load or shift in low gear
More Fuel Consumption	Air cleaner is dirty/choked	Clean air cleaner
	Overloading of engine	Reduce load or shift to low gear
	Improper valve clearance	Check and adjust
	Implement setting improper	Adjust it and take instrument from dealer for right
	Less engine temp.	Check injector and service
	Fuel injection nozzle faulty	Check and service through dealer

HYDRAULIC		
Excessive Heating of Oil	Improper inflation pressure	Check and adjust according to specified
	Oil level is high or less	Check and maintain proper level
	Hydraulic strainer choked	Clean/Replace
	Mechanical linkage may faulty	Contact your authorized dealer
Linkage Goes Down Slowly	Bush tight	Contact your authorized dealer
	Response valve setting improper	Contact your authorized dealer
Linkage Not Lift Fully	Improper lift arm setting	Contact your authorized dealer
	Improper internal adjustment	Contact your authorized dealer
TPL Not Respond to Lifting While Operating Hydraulic	Linkage connection not joint properly	Contact your authorized dealer
	Heavy load on linkage	Contact your authorized dealer

Hydraulic System Not Working Properly	Response valve setting very low	Check valve by your dealer
	Oil level low	Check and top up
	Hydraulic strainer choked	Clean/Replace
	Hydraulic system faulty	Check through authorized dealer
	Hydraulic pump not working	Contact your authorized dealer
	Oil Grade is not Correct	Replace the oil with suitable grade as per ambient condition
BRAKES		
Noise While Applying Brakes Tractor Goes in One Side	Wrong adjustment of brakes	Check
	Both brakes are not set properly	Adjust
Brakes Works When Fully Pressed	Wrong adjustment of brake pedal	Check and adjust

ELECTRICAL		
Electrical System Not Working	Battery terminal loose or rusting of terminal	Clean and tight the terminals
	Less specific gravity	Replace or fill electrolyte up to level
Starter Motor Not Working	Battery terminal loose/Battery discharged	Tightened/Recharge or replace battery
	Faulty starter motor	For repair contact your dealer
Battery Not Charging	Loose or rusted terminals	Clean and tight the terminals
	Belt loose	Check belt tension
	Faulty battery	Replace

1st SERVICE COUPON

1ST LABOUR SERVICE COUPON	 CAPTAIN TRACTORS PVT. LTD.	
50 HOURS	1 ST LABOUR SERVICE COUPON	50 HOURS
CHASSIS NUMBER: -	CHASSIS NUMBER :	
	ENGINE NUMBER :	
ENGINE NUMBER: -	TRACTOR MODEL :	
	TRACTOR HOURS :	
TRACTOR MODEL: -	DATE OF SERVICE :	
	DATE OF SALE :	
TRACTOR HOURS: -	OWNER'S NAME :	
	DEALER NAME :	
DATE OF SERVICE: -	COMMENTS	
<ul style="list-style-type: none"> Valid for 1 Month or 50 Hours Which Ever is Earlier from Date of Delivery I hereby certify that service has been carried out to my entire satisfaction 	<ul style="list-style-type: none"> Valid for 1 Month or 50 Hours Which Ever is Earlier from Date of Delivery Cost of oil filter and material to be paid by tractor owner I hereby certify that service has been carried out to my entire satisfaction Warranty stands null and void if this service is not carried out as stipulated 	
Sign of Customer	Sign of Customer	
Dealer Seal & Sign	Dealer Seal & Sign	

WASH TRACTOR THOROUGHLY & GREASE/LUBRICATE ALL POINT AS SHOWN IN LUBRICATION CHART.

REPLACE: -	CLEAN & ADJUST: -
<ul style="list-style-type: none"> • Engine Oil • Engine Oil Filter • Fuel Filter • Fuel Strainer Filter • Suction Filter 	<ul style="list-style-type: none"> • Tappet Clearance • Clutch Pedal Free Play • Brake Pedal Free Play • Tyre Air Pressure
CHECK & TIGHTEN: -	CLEAN: -
<ul style="list-style-type: none"> • Retighten All Fasteners • Fan Belt Tension • Front Wheel Bolts • Rear Wheel Bolts • Cylinder Head Bolts 	<ul style="list-style-type: none"> • Air Cleaner Element • Breather Assembly • Battery Terminal & Cover with Petroleum Jelly • Fuel Strainer Filter
CHECK: -	TOP UP (IF REQUIRED): -
<ul style="list-style-type: none"> • Radiator Coolant Level • Transmission Oil • Working of Hydraulic • Working of Brake • Working of Steering • Front Differential Oil • Battery Water Level • Battery Terminals • Working of Gauges & Meters • Working of Alternator • Working of Starter Motor • Tyre Pressure • Any Kind of Leakages • Specific Gravity of Battery 	<ul style="list-style-type: none"> • Oil Level in Rear Transmission • Front Differential Oil Level • Battery Water Level
	ROAD TEST: -
	<ul style="list-style-type: none"> • Working of Engine • Working of Clutch • Working of Brake • Working of Steering • Working of Gears

2ND SERVICE COUPON

2ND LABOUR SERVICE COUPON	 CAPTAIN TRACTORS PVT. LTD.	
250 HOURS	2 ND LABOUR SERVICE COUPON	250 HOURS
CHASSIS NUMBER: -	CHASSIS NUMBER :	
	ENGINE NUMBER :	
ENGINE NUMBER: -	TRACTOR MODEL :	
	TRACTOR HOURS :	
TRACTOR MODEL: -	DATE OF SERVICE :	
	DATE OF SALE :	
TRACTOR HOURS: -	OWNER'S NAME :	
	DEALER NAME :	
DATE OF SERVICE: -	COMMENTS	
<ul style="list-style-type: none"> Valid for 3 Month or 250 Hours Which Ever is Earlier from Date of Delivery I hereby certify that service has been carried out to my entire satisfaction 	<ul style="list-style-type: none"> Valid for 3 Month or 250 Hours Which Ever is Earlier from Date of Delivery Cost of oil filter and material to be paid by tractor owner I hereby certify that service has been carried out to my entire satisfaction Warranty stands null and void if this service is not carried out as stipulated 	
Sign of Customer	Sign of Customer	
Dealer Seal & Sign	Dealer Seal & Sign	

**WASH TRACTOR THOROUGHLY & GREASE/LUBRICATE
ALL POINT AS SHOWN IN LUBRICATION CHART.**

<p>REPLACE: -</p> <ul style="list-style-type: none"> • Engine Oil • Engine Oil Filter • Fuel Filter • Fuel Strainer Filter • Suction Filter 	<p>CLEAN & ADJUST: -</p> <ul style="list-style-type: none"> • Tappet Clearance • Clutch Pedal Free Play • Brake Pedal Free Play • Tyre Air Pressure
<p>CHECK & TIGHTEN: -</p> <ul style="list-style-type: none"> • Retighten All Fasteners • Fan Belt Tension • Front Wheel Bolts • Rear Wheel Bolts • Cylinder Head Bolts 	<p>CLEAN: -</p> <ul style="list-style-type: none"> • Air Cleaner Element • Breather Assembly • Battery Terminal & Cover with Petroleum Jelly • Fuel Strainer Filter
<p>CHECK: -</p> <ul style="list-style-type: none"> • Radiator Coolant Level • Transmission Oil • Working of Hydraulic • Working of Brake • Working of Steering • Front Differential Oil • Battery Water Level • Battery Terminals • Working of Gauges & Meters • Working of Alternator • Working of Starter Motor • Tyre Pressure • Any Kind of Leakages • Specific Gravity of Battery 	<p>TOP UP (IF REQUIRED): -</p> <ul style="list-style-type: none"> • Oil Level in Rear Transmission • Front Differential Oil Level • Battery Water Level <p>ROAD TEST: -</p> <ul style="list-style-type: none"> • Working of Engine • Working of Clutch • Working of Brake • Working of Steering • Working of Gears

3RD SERVICE COUPON

3RD LABOUR SERVICE COUPON	 CAPTAIN TRACTORS PVT. LTD.	
500 HOURS	3 RD LABOUR SERVICE COUPON	500 HOURS
CHASSIS NUMBER: -	CHASSIS NUMBER :	
	ENGINE NUMBER :	
ENGINE NUMBER: -	TRACTOR MODEL :	
	TRACTOR HOURS :	
TRACTOR MODEL: -	DATE OF SERVICE :	
	DATE OF SALE :	
TRACTOR HOURS: -	OWNER'S NAME :	
	DEALER NAME :	
DATE OF SERVICE: -	COMMENTS	
<ul style="list-style-type: none"> • Valid for 6 Month or 500 Hours Which Ever is Earlier from Date of Delivery • I hereby certify that service has been carried out to my entire satisfaction 	<ul style="list-style-type: none"> • Valid for 6 Month or 500 Hours Which Ever is Earlier from Date of Delivery • Cost of oil filter and material to be paid by tractor owner • I hereby certify that service has been carried out to my entire satisfaction • Warranty stands null and void if this service is not carried out as stipulated 	
Sign of Customer	Sign of Customer	
Dealer Seal & Sign	Dealer Seal & Sign	

WASH TRACTOR THOROUGHLY & GREASE/LUBRICATE ALL POINT AS SHOWN IN LUBRICATION CHART.

<p>REPLACE: -</p> <ul style="list-style-type: none"> • Engine Oil • Engine Oil Filter • Fuel Filter • Fuel Strainer Filter • Suction Filter 	<p>CLEAN & ADJUST: -</p> <ul style="list-style-type: none"> • Tappet Clearance • Clutch Pedal Free Play • Brake Pedal Free Play • Tyre Air Pressure
<p>CHECK & TIGHTEN: -</p> <ul style="list-style-type: none"> • Retighten All Fasteners • Fan Belt Tension • Front Wheel Bolts • Rear Wheel Bolts • Cylinder Head Bolts 	<p>CLEAN: -</p> <ul style="list-style-type: none"> • Air Cleaner Element • Breather Assembly • Battery Terminal & Cover with Petroleum Jelly • Fuel Strainer Filter
<p>CHECK: -</p> <ul style="list-style-type: none"> • Radiator Coolant Level • Transmission Oil • Working of Hydraulic • Working of Brake • Working of Steering • Front Differential Oil • Battery Water Level • Battery Terminals • Working of Gauges & Meters • Working of Alternator • Working of Starter Motor • Tyre Pressure • Any Kind of Leakages • Specific Gravity of Battery 	<p>TOP UP (IF REQUIRED): -</p> <ul style="list-style-type: none"> • Oil Level in Rear Transmission • Front Differential Oil Level • Battery Water Level <p>ROAD TEST: -</p> <ul style="list-style-type: none"> • Working of Engine • Working of Clutch • Working of Brake • Working of Steering • Working of Gears

4TH SERVICE COUPON

4TH LABOUR SERVICE COUPON	 CAPTAIN TRACTORS PVT. LTD.	
750 HOURS	4 TH LABOUR SERVICE COUPON	750 HOURS
CHASSIS NUMBER: -	CHASSIS NUMBER :	
	ENGINE NUMBER :	
ENGINE NUMBER: -	TRACTOR MODEL :	
	TRACTOR HOURS :	
TRACTOR MODEL: -	DATE OF SERVICE :	
	DATE OF SALE :	
TRACTOR HOURS: -	OWNER'S NAME :	
	DEALER NAME :	
DATE OF SERVICE: -	COMMENTS	
<ul style="list-style-type: none"> Valid for 12 Month or 750 Hours Which Ever is Earlier from Date of Delivery I hereby certify that service has been carried out to my entire satisfaction 	<ul style="list-style-type: none"> Valid for 12 Month or 750 Hours Which Ever is Earlier from Date of Delivery Cost of oil filter and material to be paid by tractor owner I hereby certify that service has been carried out to my entire satisfaction Warranty stands null and void if this service is not carried out as stipulated 	
Sign of Customer	Sign of Customer	
Dealer Seal & Sign	Dealer Seal & Sign	

**WASH TRACTOR THOROUGHLY & GREASE/LUBRICATE
ALL POINT AS SHOWN IN LUBRICATION CHART.**

REPLACE: -	CLEAN & ADJUST: -
<ul style="list-style-type: none"> • Engine Oil • Engine Oil Filter • Fuel Filter • Fuel Strainer Filter • Suction Filter • Air Cleaner Element • Transmission Oil • Front Differential Oil • Suction Strainer Filter 	<ul style="list-style-type: none"> • Tappet Clearance • Clutch Pedal Free Play • Brake Pedal Free Play • Tyre Air Pressure
CHECK & TIGHTEN: -	CLEAN: -
<ul style="list-style-type: none"> • Retighten All Fasteners • Fan Belt Tension • Front Wheel Bolts • Rear Wheel Bolts • Cylinder Head Bolts 	<ul style="list-style-type: none"> • Breather Assembly • Battery Terminal & Cover with Petroleum Jelly • Fuel Strainer Filter
CHECK: -	TOP UP (IF REQUIRED): -
<ul style="list-style-type: none"> • Radiator Coolant Level • Transmission Oil • Working of Hydraulic • Working of Brake • Working of Steering • Battery Water Level • Battery Terminals • Working of Gauges & Meters • Working of Alternator • Working of Starter Motor • Tyre Pressure • Any Kind of Leakages • Specific Gravity of Battery 	<ul style="list-style-type: none"> • Oil Level in Rear Transmission • Front Differential Oil Level • Battery Water Level
	ROAD TEST: -
	<ul style="list-style-type: none"> • Working of Engine • Working of Clutch • Working of Brake • Working of Steering • Working of Gears

5TH SERVICE COUPON

5TH LABOUR SERVICE COUPON	 CAPTAIN TRACTORS PVT. LTD.	
1000 HOURS	5 TH LABOUR SERVICE COUPON	1000 HOURS
CHASSIS NUMBER: -	CHASSIS NUMBER :	
	ENGINE NUMBER :	
ENGINE NUMBER: -	TRACTOR MODEL :	
	TRACTOR HOURS :	
TRACTOR MODEL: -	DATE OF SERVICE :	
	DATE OF SALE :	
TRACTOR HOURS: -	OWNER'S NAME :	
	DEALER NAME :	
DATE OF SERVICE: -	COMMENTS	
<ul style="list-style-type: none"> Valid for 18 Month or 1000 Hours Which Ever is Earlier from Date of Delivery I hereby certify that service has been carried out to my entire satisfaction 	<ul style="list-style-type: none"> Valid for 18 Month or 1000 Hours Which Ever is Earlier from Date of Delivery Cost of oil filter and material to be paid by tractor owner I hereby certify that service has been carried out to my entire satisfaction Warranty stands null and void if this service is not carried out as stipulated 	
Sign of Customer	Sign of Customer	
Dealer Seal & Sign	Dealer Seal & Sign	

WASH TRACTOR THOROUGHLY & GREASE/LUBRICATE ALL POINT AS SHOWN IN LUBRICATION CHART.

REPLACE: -	CLEAN & ADJUST: -
<ul style="list-style-type: none"> • Engine Oil • Engine Oil Filter • Fuel Filter • Fuel Strainer Filter • Suction Filter • Front Differential Oil 	<ul style="list-style-type: none"> • Tappet Clearance • Clutch Pedal Free Play • Brake Pedal Free Play • Tyre Air Pressure
CHECK & TIGHTEN: -	CLEAN: -
<ul style="list-style-type: none"> • Retighten All Fasteners • Fan Belt Tension • Front Wheel Bolts • Rear Wheel Bolts • Cylinder Head Bolts 	<ul style="list-style-type: none"> • Air Cleaner Element • Breather Assembly • Battery Terminal & Cover with Petroleum Jelly • Fuel Strainer Filter
CHECK: -	TOP UP (IF REQUIRED): -
<ul style="list-style-type: none"> • Radiator Coolant Level • Transmission Oil • Working of Hydraulic • Working of Brake • Working of Steering • Front Differential Oil • Battery Water Level • Battery Terminals • Working of Gauges & Meters • Working of Alternator • Working of Starter Motor • Tyre Pressure • Any Kind of Leakages • Specific Gravity of Battery 	<ul style="list-style-type: none"> • Oil Level in Rear Transmission • Front Differential Oil Level • Battery Water Level
	ROAD TEST: -
	<ul style="list-style-type: none"> • Working of Engine • Working of Clutch • Working of Brake • Working of Steering • Working of Gears



CAPTAIN AGRI MACHINERY EXIM LLP.

C/o. Captain Tractors Pvt. Ltd. Padavala Road, Veraval (Shapar), Taluka : Kotda Sangani,

District : Rajkot, Gujarat, India. Pincode - 360024

Phone/fax : +91 2827-252547, 253916-17, 9726270707, 9099433133

Email : info@captaintractors.com, Web : www.captaintractors.com

MADE IN INDIA